

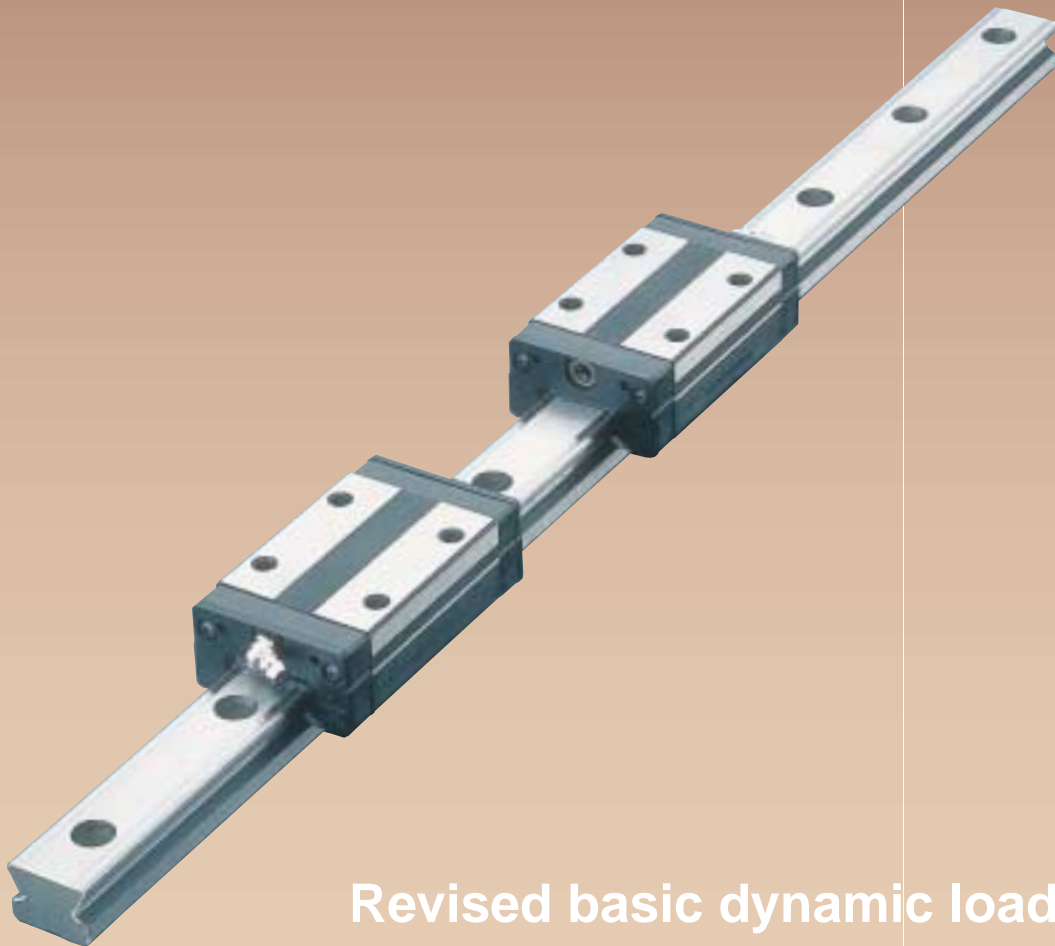

Advantages of Caged Ball™ Technology

- High speed performance
- Low noise design, long service life
- Long-term maintenance-free operation
- Reduction in rolling resistance variation

SSR



Revised basic dynamic load ratings

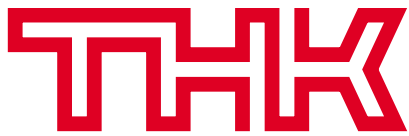

Radial type LM Guide® with Caged Ball™ Technology

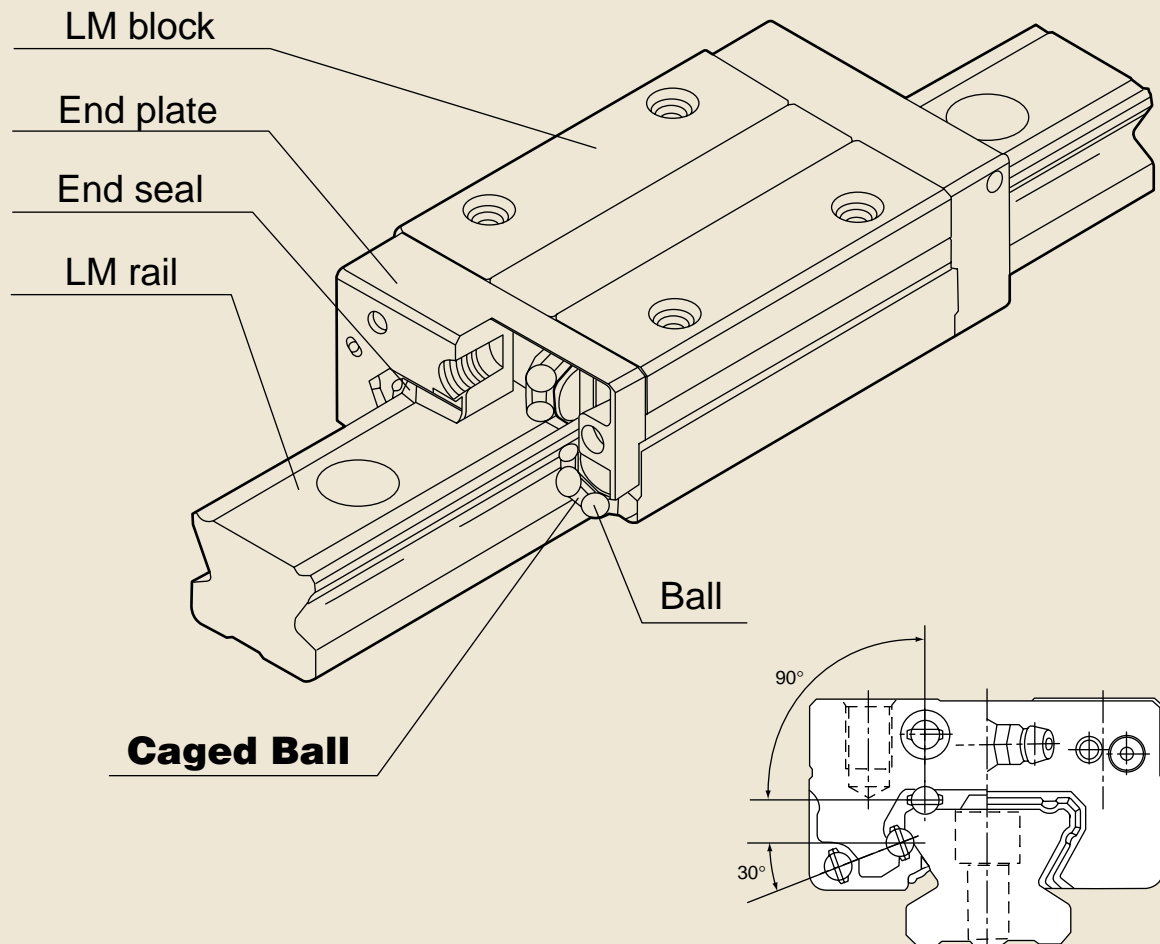

Figure 1 Structure of type SSR-XW

Cross-sectional views

The radial type LM Guide® (linear motion guide) with Caged Ball™ Technology for low noise, long-term maintenance-free, and higher speed operation

Friction of the balls

■Linear motion guide

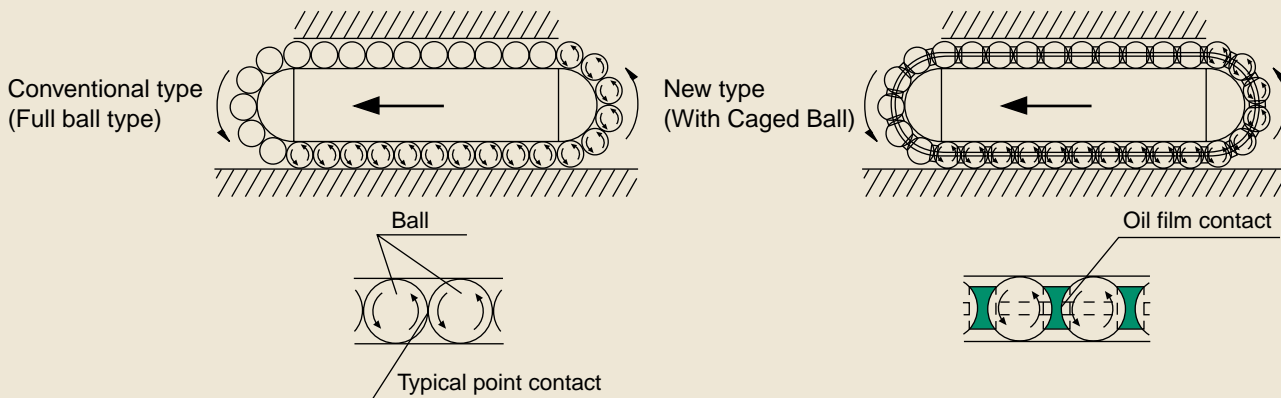

■Rotary ball bearing

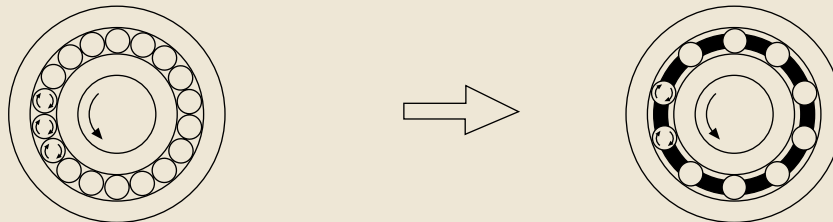

In the first stage of development (Full ball type)

- Adjacent balls contact each other at a point. As a result, the contact stress is large and the oil film breaks down due to friction.
- The life becomes shorter.

Present bearing (With Caged Ball)

- The life is extended due to the absence of friction.
- Heat generation during high-speed rotation is limited due to the absence of the friction between adjacent balls.
- The balls do not contact each other. Noise does not arise from the metal to metal contact.
- Balls move smoothly because they are positioned evenly.
- The lubricating oil retained between the balls provides excellent lubrication and long life.

At the time ball bearings were invented, they had no retainers and caused loud noise. Also, they had short running life and were unable to be operated at high speeds.

20 years later, bearings with retainers were developed. This type was quieter in operation and was capable of high rotational speeds. Although there are less balls, it provided excellent running life and contributes to the major success of the product. The history of the needle bearing revealed how the quality improved through the use of retainers. Balls at their point of contact slip against each other in opposite directions and at twice the speed of each of their rotations, which results in severe wear, louder noise and a shorter running life.

The massive pressures and metal to metal slip between the balls also break down the oil film, normally film breaks down at 3 kg/mm² of surface pressure.

Alternatively, retainers and balls contact each other in larger areas, which prevents the break down of oil and provides for quieter operation, high rotational speeds, and longer running life.

As a result of our long-term experience and new manufacturing technologies, THK has developed a new Caged Ball technology, which made smooth movement possible. Type SSR using Caged Ball technology is equipped with a ball circulating section, and its features are as follows.

Low Noise and Favorable Sound Quality

Since the balls move in an orderly manner due to the presence of the ball cages, the metallic sound produced by collision between adjacent balls is eliminated, thereby resulting in low noise levels and favorable sound quality.

Long service life, long-term maintenance-free operation

Adjacent balls, separated by the ball cage, do not rub against each other and produce friction. As a result, the balls are not subject to wear and tear. In addition, the grease retention has been enhanced, providing long service life, long-term maintenance-free operation.

Excellent high-speed performance

Caged Ball exhibits excellent high-speed performance through reduced heat generation due to lower bearing stress and half ball contact velocity. The life of the balls is also prolonged due to the elimination of the friction and wear between adjacent balls.

Super Smooth movement

Smooth movement with less variation of torque can be obtained as the balls are lined uniformly and circulated.

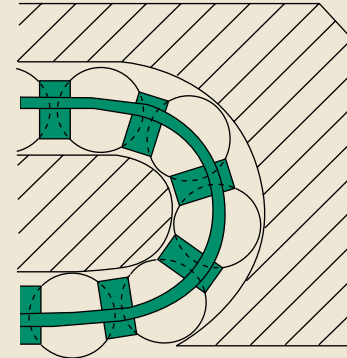
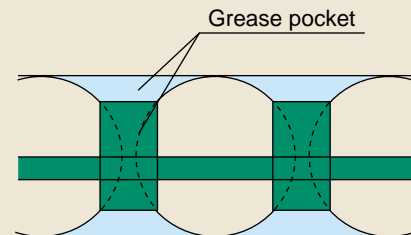

Figure 2 Ball circulating section



The grease circulates with the aid of the ball cage.

Figure 3 Grease pocket

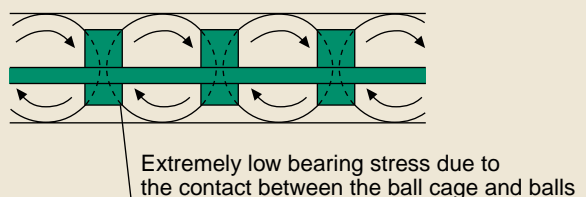
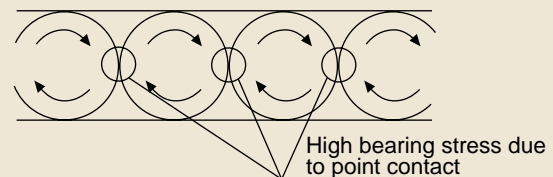

Figure 4 Friction

Since the effect of the ball cages eliminates friction between adjacent balls while also enhancing the retention of grease, the basic dynamic load ratings have been revised.

Model number	Basic load rating C kN	Model number	Basic load rating C kN
SSR15XWY(M)	14.7	SR15W(M)	9.51
SSR20XW(M)	19.6	SR20W(M)	12.5
SSR25XWY(M)	31.5	SR25WY(M)	20.3
SSR30XW(M)	46.5	SR30W(M)	30
SSR35XW(M)	64.6	SR35W(M)	41.7

Comparison of basic dynamic load ratings between the SNR type of LM Guide with ball cages and the NR type of packed ball LM Guide.

■Noise level data

Figure 5 compares the data concerning noise level between type SSR and the conventional types. The variable condition for noise comparison is the moving speed in meter per minute. These graphs show that type SSR generates lower noise compared to that of the conventional types.

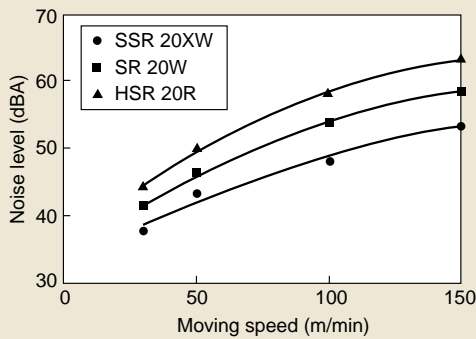

Figure 5 Noise level comparison with respect to the speed (m/min)

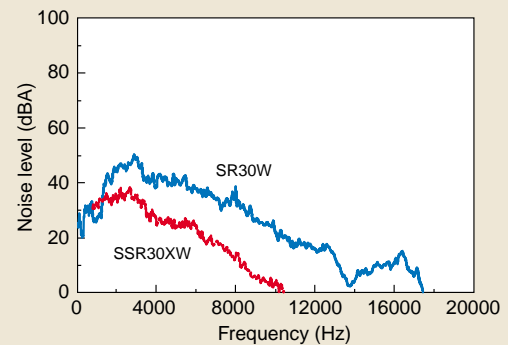

Figure 6 Frequency characteristics (Speed: 100m/min)

■Durability test data

Achieving 40000 km of running distance with the initial sealed grease!!

Condition 1) Sample type :SSR25XWUU
 Speed :300 m/min
 Stroke :2800 mm
 Lubricant :AFA grease
 Initial sealed amount :2 cm³
 Applied load :None
 Travel distance :40000 km

Condition 2) Sample type :SSR25XWUUC1
 Speed :300 m/min
 Stroke :2800 mm
 Lubricant :AFA grease
 Initial sealed amount:2 cm³
 Applied load :1 kN
 Travel distance :30000 km

■Less fluctuated rolling resistance

Fluctuations of rolling resistance are more conspicuous in the use of the unit at vertical position than at other positions. Fig. 7 presents rolling resistance data of the conventional product, and Fig. 8 presents the same for type SSR25XW. Type SSR provides almost no fluctuations of rolling resistance even at the vertical application and ensures stable, smooth movement compared to the conventional type.

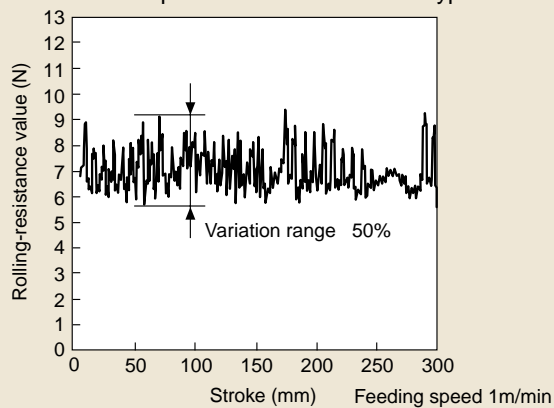

Figure 7 Rolling resistance in use at vertical position (Conventional type)

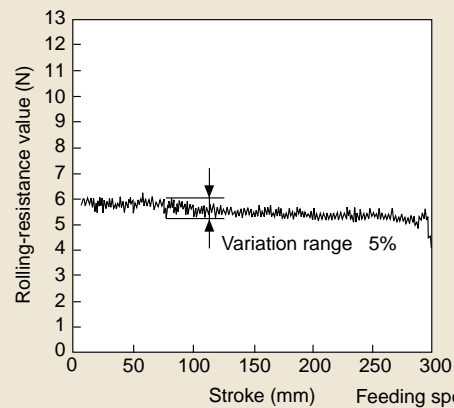
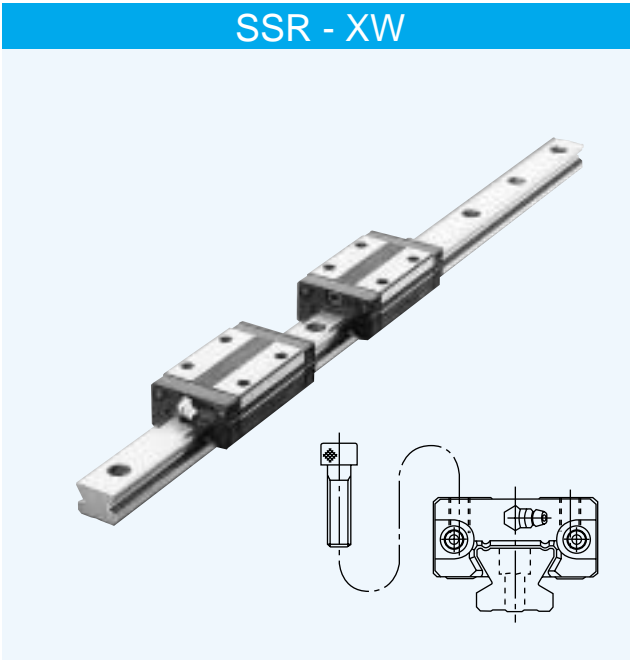

Figure 8 Rolling resistance in use at vertical position (SSR25XW)

Types and features

SSR - XW



Type SSR-XW has low profile, so it is compact and strong for radial load.

SSR - XV

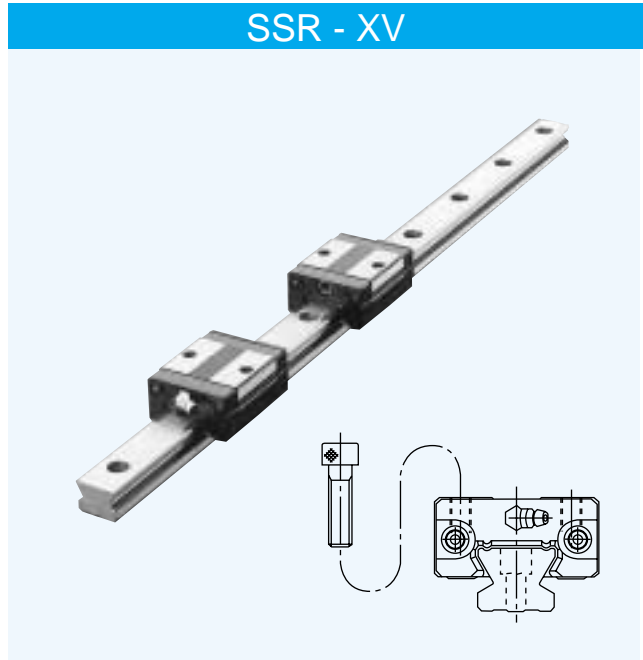

Type SSR-XV is similar to type SSR-XW except that the LM block is shorter. This saves space for mounting.

SSR - XTB

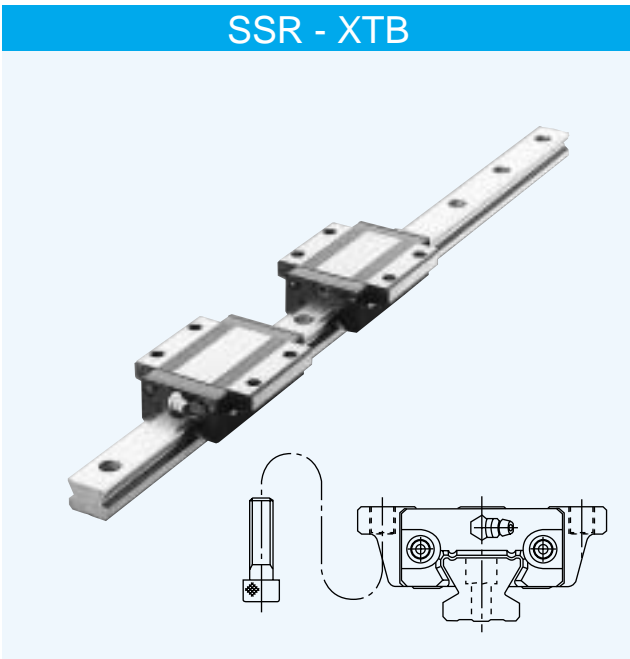

Since the LM block can be installed from underneath, it is useful for when through holes for mounting bolts are not available on top table.

Load ratings and life

Types SSR can support loads in the radial, reverse radial and lateral directions.

The basic load ratings listed in the dimension tables show the load ratings in the radial direction.

Life calculation

The following equation gives the life of types SNR/SNS.

$$L = \left(\frac{f_t \cdot f_c}{f_w} \cdot \frac{C}{P_c} \right)^3 \cdot 50$$

L : Rated life (km)

(Total distance of travel reached without flaking by 90% of a group of the same linear motion system that are operated independently under the same conditions)

C : Basic dynamic load rating (N)

(The basic dynamic load rating (C) refers to the load that does not vary in direction or magnitude such that the rated service life L is equal to 50 Km when a group of identical LM Guides are individually operated under the same conditions.)

P_c : Design load (N)

f_t : Temperature factor

(See General Catalog.)

f_c : Contact factor

(See General Catalog.)

f_w : Load factor

(See General Catalog.)

Given rated life(L) calculated by the above equation and assuming that the length of stroke and the reciprocating rate are constant, the life in terms of time can be calculated by using the following equation.

$$L_h = \frac{L \times 10^3}{2 \times l_s \times n_1 \times 60}$$

L_h : Life in terms of time (hr)

l_s : Stroke length (m)

n₁ : Number of reciprocating motions per minute (min⁻¹)

Load ratings in various directions

Load ratings

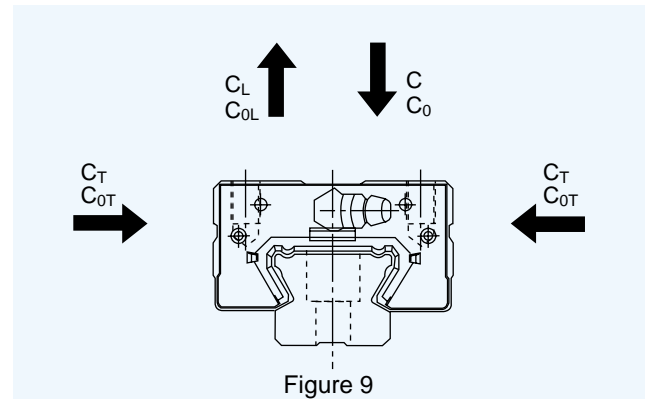

Type SSR can support loads in the radial, reverse radial and lateral directions. The basic load ratings show the load ratings in the radial direction in Figure 9, and they are listed in the dimension tables. The reverse radial and lateral load ratings are obtained from the Table 1.

Table 1 Load ratings of type SSR in various directions

Direction	Basic dynamic load rating	Basic static load rating
Radial	C	C ₀
Reverse radial	C _L =0.50C	C _{OL} =0.50C ₀
Lateral	C _T =0.53C	C _{OT} =0.43C ₀

Equivalent load

When the LM block of type SSR is subjected to reverse radial and lateral loads simultaneously, the equivalent load can be calculated by using the following equation.

$$P_E = X \cdot P_L + Y \cdot P_T$$

P_E : Equivalent load (N)

· Reverse radial

· Lateral

P_L : Reverse radial load(N)

P_T : Lateral load(N)

X, Y : Equivalent factors (Table 2)

Table 2 Equivalent factors of type SSR

P _E	X	Y
Reverse radial equivalent load	1	1.155
Lateral equivalent load	0.866	1

Accuracy standard

The accuracy of type SSR is classified into normal, high, precision, super precision, and ultra precision grade as shown in Table 4.

Permissible moment load

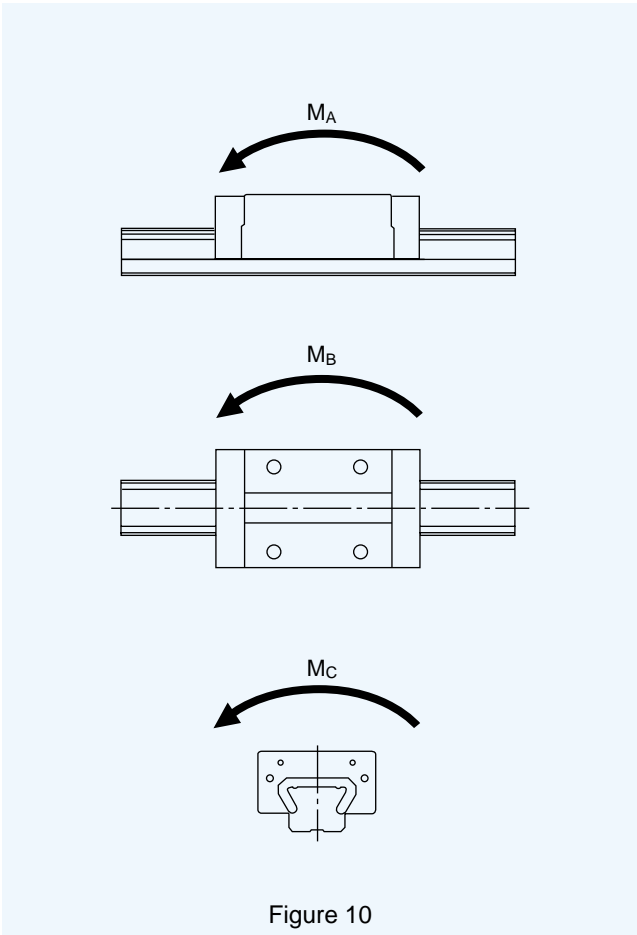

Type SSR can take moment load in all three directions with only one LM block. Table 3 lists the values for the permissible moment load with one LM block and two blocks tandem (except M_C) in three directions, M_A , M_B and M_C .

Table 3 Static permissible moment of type SSR Unit: kN·m

Direction Model No.	M_A		M_B		M_C
	One block	Two blocks tandem	One block	Two blocks tandem	One block
SSR 15 XV	0.02	0.13	0.02	0.11	0.04
SSR 15 XW/XTB	0.05	0.28	0.04	0.24	0.07
SSR 20 XV	0.03	0.19	0.02	0.16	0.07
SSR 20 XW/XTB	0.07	0.43	0.06	0.37	0.12
SSR 25 XV	0.05	0.37	0.04	0.32	0.12
SSR 25 XW/XTB	0.15	0.84	0.12	0.73	0.21
SSR 30 XW	0.25	1.41	0.21	1.22	0.36
SSR 35 XW	0.40	2.19	0.34	1.89	0.60

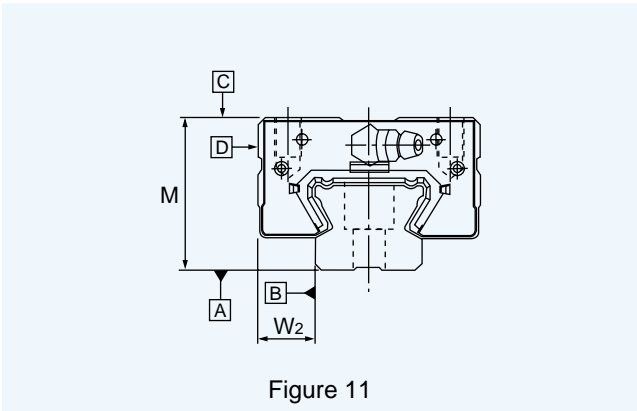

Figure 11

Table 4 Accuracy standard Unit : mm

Model number	Accuracy grade	Normal	High	Precision	Super-precision	Ultra-precision
	Item	No symbol	H	P	SP	UP
SSR 15X SSR 20X	Tolerance of height M	±0.1	±0.03	0 -0.03	0 -0.015	0 -0.008
	Difference of height M	0.02	0.01	0.006	0.004	0.003
	Tolerance of width W2	±0.1	±0.03	0 -0.03	0 -0.015	0 -0.008
	Difference of width W2	0.02	0.01	0.006	0.004	0.003
	Running parallelism of LM block surface [C] with respect to surface [A]	C (Refer to Figure 12)				
	Running parallelism of LM block surface [D] with respect to surface [B]	D (Refer to Figure 12)				
SSR 25X SSR 30X SSR 35X	Tolerance of height M	±0.1	±0.04	0 -0.04	0 -0.02	0 -0.01
	Difference of height M	0.02	0.015	0.007	0.005	0.003
	Tolerance of width W2	±0.1	±0.04	0 -0.04	0 -0.02	0 -0.01
	Difference of width W2	0.03	0.015	0.007	0.005	0.003
	Running parallelism of LM block surface [C] with respect to surface [A]	C (Refer to Figure 12)				
	Running parallelism of LM block surface [D] with respect to surface [B]	D (Refer to Figure 12)				

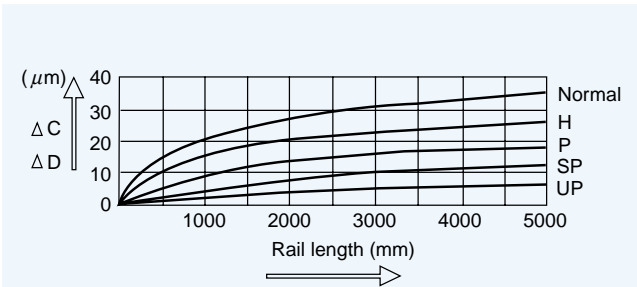

Figure 12 LM rail length and running parallelism

Radial clearance

Table 5 lists the radial clearance of type SSR.

Table 5 Radial clearance of type SSR

Unit: μm

Symbol Model number	Normal	Light preload
	No symbol	C1
SSR 15 X	-4 ~ +2	-10 ~ -4
SSR 20 X	-5 ~ +2	-12 ~ -5
SSR 25 X	-6 ~ +3	-15 ~ -6
SSR 30 X	-7 ~ +4	-18 ~ -7
SSR 35 X	-8 ~ +4	-20 ~ -8

Contamination protection

Type SSR is provided with end seals and side seals as a standard feature for contamination protection.

End seals

They are provided as a standard feature.

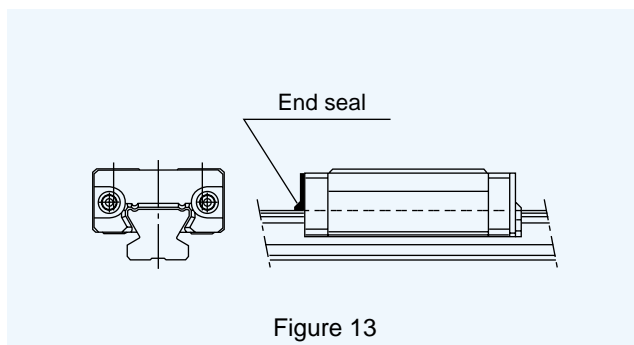

Scrapers

Scrapers for eliminating relatively large foreign matter such as welding spatter are available.

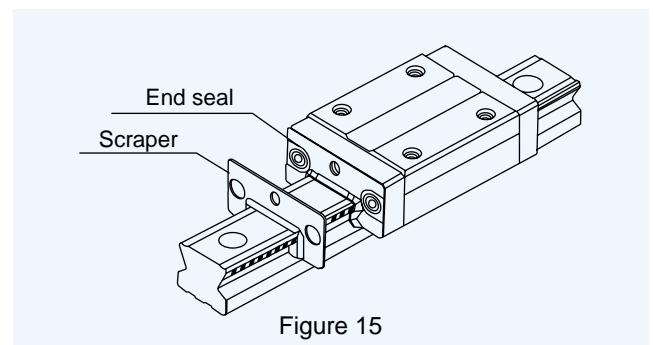

Double seals

Double seals are available for better contamination protection.

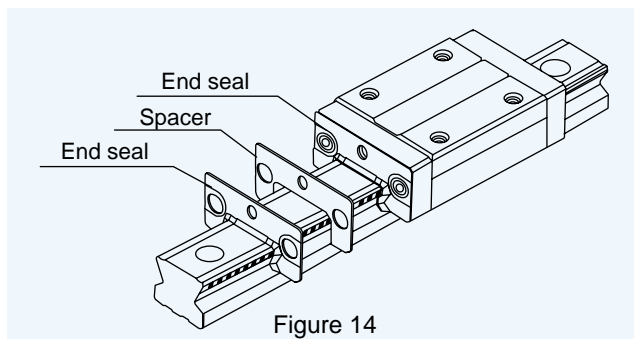

Side seals

To prevent the contamination from under the LM block, side seals are available.

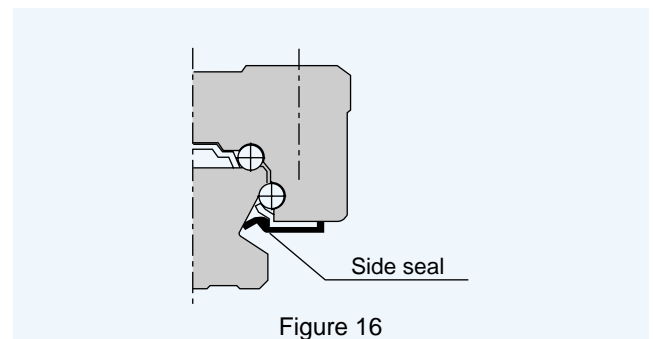

Symbols for contamination protection system

When contamination protection is required, specify according to the code shown in Table 6.

Some model numbers are not applicable. Please be sure to refer to Table 7.

Even with applicable models, the entire block length may vary according to the type used. Add the increased dimensions to the corresponding "L" value shown in the dimension tables.

Table 6

Protection system	Symbol
With end seal (on both ends)	UU
With end seals, side seals	SS
With end seals, side seals, and scrapers	ZZ
With double seals, side seals	DD
With double seals, side seals, and scrapers	KK

Seal Resistance

Regarding to type SSR with "SS" seals (end seals and side seals on both ends), Table 7 shows the value of maximum seal resistance for one LM block when lubricant is applied.

Table 7 Maximum seal resistance of type SSR

Unit: N

Model number	Seal resistance
SSR 15 X	2
SSR 20 X	2.6
SSR 25 X	3.5
SSR 30 X	4.9
SSR 35 X	6.3

Special bellows: type JSSR-X

The dimensions of type JSSR-X, the special bellows for type SSR, are shown below. Please specify the model number shown below.

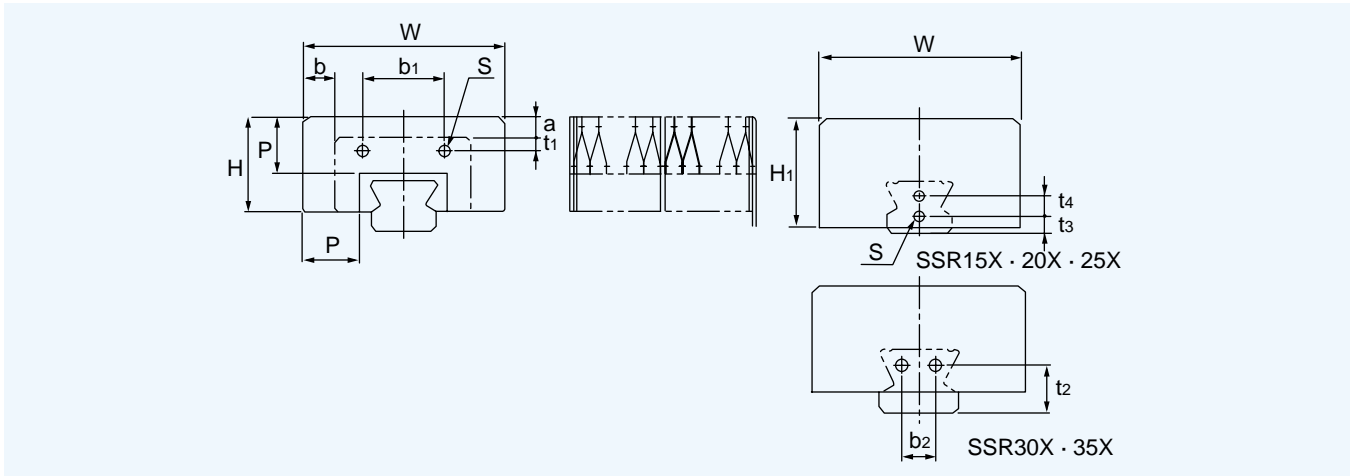

Unit: mm

Model number	Main dimensions											Mounting bolt S	a	b	A ($\frac{L_{max}}{L_{min}}$)	Applicable types
	W	H	H ₁	P	b ₁	t ₁	b ₂	t ₂	t ₃	t ₄						
JSSR15X	51	24	26	15	20.5	4.7	—	—	8	—	M3×0.5× 5 ℓ	5	8.5	5	SSR 15X	
JSSR20X	58	26	30	15	25	4.2	—	—	6	6	M3×0.5× 5 ℓ	4	8	5	SSR 20X	
JSSR25X	71	33	38	20	29	5	—	—	6	7	M3×0.5× 5 ℓ	7	11.5	7	SSR 25X	
JSSR30X	76	37.5	37.5	20	35	9	12	17	—	—	M3×0.5× 5 ℓ	3	8	7	SSR 30X	
JSSR35X	84	39	39	20	44	7	14	20	—	—	M3×0.5× 5 ℓ	2	7	7	SSR 35X	

Note 1 : The expansion rate differs (A minus 1.5 as guide line) when units other than those intended for horizontal position, such as usage at vertical or wall-hung position, are used. When ordering, please specify the position of intended use.

Note 2 : If bellows are attached to both ends of LM block, a grease fitting cannot be attached. Please contact THK about this.

Model number coding

JSSR35X — 60/420

Bellows dimension $\left(\frac{\text{Folded length}}{\text{Extended length}} \right)$

Model number ... for SSR35X

Note: The bellows length is calculated as follows:

$$L_{min} = \frac{S}{(A - 1)} \quad S : \text{Stroke length (mm)}$$

$$L_{max} = L_{min} \cdot A \quad A : \text{Expansion rate}$$

Notes on use

Shoulder height and bottom corner of installation surfaces

Normally, a shoulder is provided on the installation surface for the LM block and/or the rail to enable easy assembling and accurate alignment.

For block installation, it is necessary to limit the height of shoulder less than H2 (Table 8) or to clear D (Table 8) protruded resin mold.

For rail installation, shoulder height H1 should be less than E (Table 8).

Also, for both block and rail installation, the bottom corner of shoulder should have relief or radius less than r (Table 8).

Table 8 Height and radius of bottom corner

Unit: mm

Model number	Radius of bottom corner r (maximum)	Shoulder height accommodating LM rail H ₁	Shoulder maximum height accommodating LM block H ₂	E	D
SSR15X	0.5	3.8	5.5	4.5	0.3
SSR20X	0.5	5	7.5	6	0.3
SSR25X	1.0	5.5	8	6.8	0.4
SSR30X	1.0	8	11.5	9.5	0.4
SSR35X	1.0	9	16	11.5	0.4

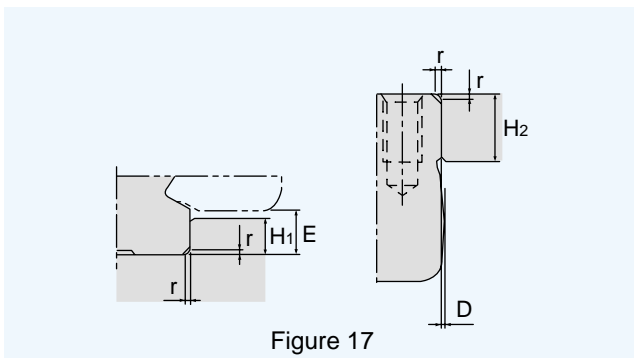



Figure 17

- Since special resin is used, do not use LM block at 80°C or higher.
- LM block is a precision resin component, so it may be damaged if dropped. Please be careful when handling.
- Please contact THK before using LM block in special environments.

Standard and maximum lengths of LM rails

Table 9 lists the standard and maximum LM rail lengths of type SSR. If a rail is longer the corresponding maximum length is specified, the rail will be in two or more sections. If a special length is required, dimension G listed in the table is recommended. If the dimension G is too long, it makes

the rail ends insecure which may adversely affect accuracy. When two or more rails are to be connected, be sure to inform  of the overall LM rail length. The rails will be machined simultaneously in order to give precise joints.

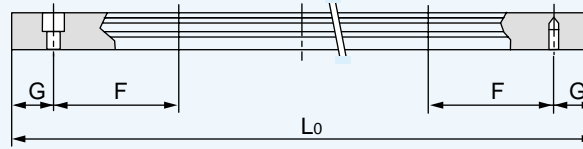



Table 9 Standard and maximum LM rail lengths for type SSR

Unit: mm

Model number	SSR 15 X	SSR 20 X	SSR 25 X	SSR 30 X	SSR 35 X
Standard LM rail length (L_0)	160	220	220	280	280
	220	280	280	360	360
	280	340	340	440	440
	340	400	400	520	520
	400	460	460	600	600
	460	520	520	680	680
	520	580	580	760	760
	580	640	640	840	840
	640	700	700	920	920
	700	760	760	1000	1000
	760	820	820	1080	1080
	820	940	940	1160	1160
	940	1000	1000	1240	1240
	1000	1060	1060	1320	1320
	1060	1120	1120	1400	1400
	1120	1180	1240	1480	1480
	1180	1240	1300	1640	1640
	1240	1300	1360	1720	1720
	1300	1360	1420	1800	1800
	1360	1420	1480	1880	1880
	1420	1480	1540	1960	1960
1480	1540	1600	2040	2040	
1540	1600	1660	2120	2120	
	1660	1720	2200	2200	
	1720	1780	2280	2280	
	1780	1840	2360	2360	
	1840	1900	2440	2440	
	1900	1960	2520	2520	
	1960	2020	2600	2600	
	2020	2080	2680	2680	
	2080	2140	2760	2760	
	2140	2200	2840	2840	
		2260	2920	2920	
		2320			
		2380			
		2440			
F	60	60	60	80	80
G	20	20	20	20	20
Maximum length	2500 (1240)	3000 (1480)	3000 (2020)	3000 (2520)	3000

Note 1: If a single-piece LM rail exceeding the corresponding maximum length listed in Table 9 is desired, please contact .

Note 2: In case of stainless steel type, standard length and maximum length will be different. Please contact .

Type SSR-XW

Standard type

Type SSR-XWM

Stainless steel type

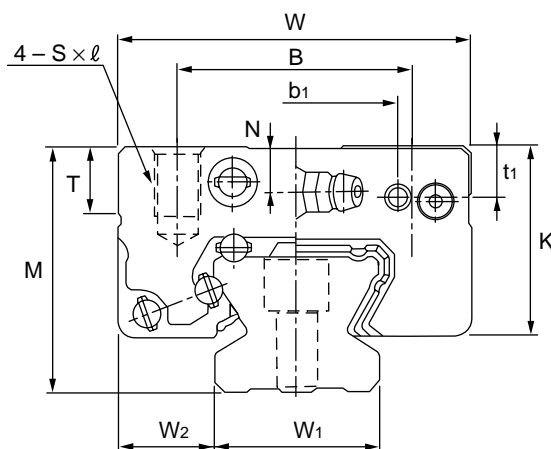

Model number	Outline dimensions			LM block dimensions												
	Height M	Width W	Length L	B	C	S × l	L ₁	T	K	N	E	N ₁	e ₁	b ₁	t ₁	d
SSR 15 XWY SSR 15 XWMY	24	34	57	26	26	M4×0.7×7	39.9	7	19.5	4.5	5.5	2.7	4	20.5	4.7	3
SSR 20 XW SSR 20 XWM	28	42	66.5	32	32	M5×0.8×8	46.6	8.5	22	5.5	12	2.8	4.8	25	4.2	3
SSR 25 XWY SSR 25 XWMY	33	48	83	35	35	M6×9	59.8	9	26.2	6	12	3.3	4.6	29	5	3
SSR 30 XW SSR 30 XWM	42	60	97	40	40	M8×12	70.7	11.5	32.5	8	12	4.5	5.6	35	9	4
SSR 35 XW	48	70	111	50	50	M8×12	80.5	16	36.5	8.5	12	4.7	6.5	44	7	4

Note : ●Symbol M specifies the use of stainless steel for LM block, rail, and the balls. This provides superior corrosion resistance and environmental performance.

●See page 7 for static permissible moment M_A, M_B, M_C.

Model number coding

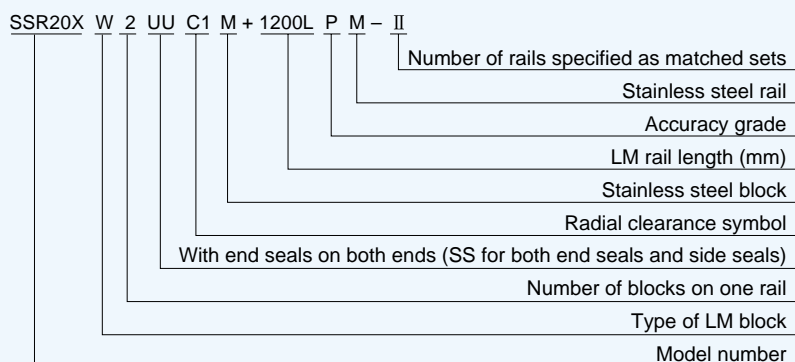

Note : This model number is for one rail unit on a one set basis.

(When two rails are to be specified as matched sets, at least two rail and block assemblies are necessary.)

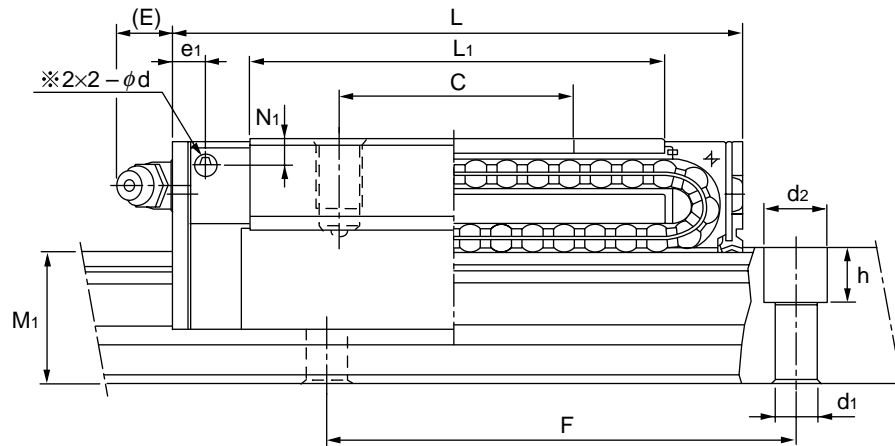

Unit: mm

Grease fitting	LM rail dimensions					Basic load rating		Mass	
	Width W_1 ± 0.05	W_2	Height M_1	Pitch F	$d_1 \times d_2 \times h$	C kN	C_0 kN	LM block kg	LM rail kg/m
PB1021B	15	9.5	12.5	60	4.5×7.5×5.3	14.7	16.5	0.15	1.2
B-M6F	20	11	15.5	60	6×9.5×8.5	19.6	23.4	0.25	2.1
B-M6F	23	12.5	18	60	7×11×9	31.5	36.4	0.4	2.7
B-M6F	28	16	23	80	7×11×9	46.5	52.7	0.8	4.3
B-M6F	34	18	27.5	80	9×14×12	64.6	71.6	1.1	6.4

● See page 12 for the standard LM rail lengths.

Note : Holes on the sides of the LM block for lubrication nipples are not made all the way through, to prevent foreign materials from entering. Please contact THK when using lubrication nipples.

Type SSR-XV

Standard type

Type SSR-XVM

Stainless steel type

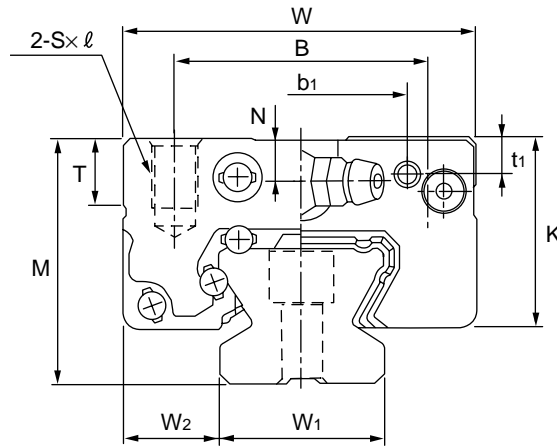

Model number	Outline dimensions			LM block dimensions											
	Height M	Width W	Length L	B	S × l	L ₁	T	K	N	E	N ₁	e ₁	b ₁	t ₁	d
SSR 15 XVY SSR 15 XVMY	24	34	41	26	M4×0.7×7	23.3	7	19.5	4.5	5.5	2.7	4	20.5	4.7	3
SSR 20 XV SSR 20 XVM	28	42	47.7	32	M5×0.8×8	27.8	8.5	22	5.5	12	2.8	4.8	25	4.2	3
SSR 25 XVY SSR 25 XVMY	33	48	60	35	M6×9	36.8	9	26.2	6	12	3.3	4.6	29	5	3

Note : ●Symbol M specifies the use of stainless steel for LM block, rail, and the balls. This provides superior corrosion resistance and environmental performance.

●See page 7 for static permissible moment M_A, M_B, M_C.

Model number coding

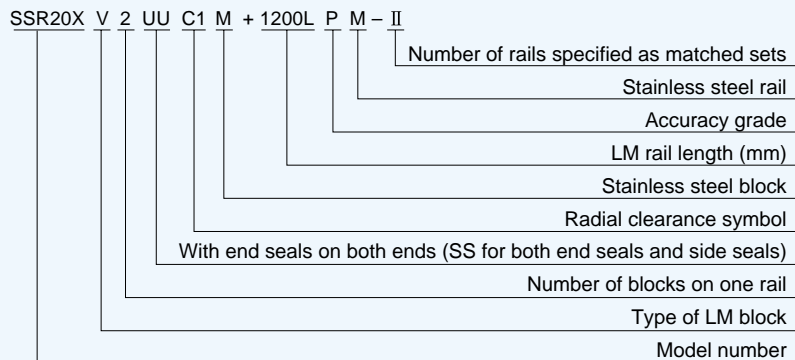

Note : This model number is for one rail unit on a one set basis.

(When two rails are to be specified as matched sets, at least two rail and block assemblies are necessary.)

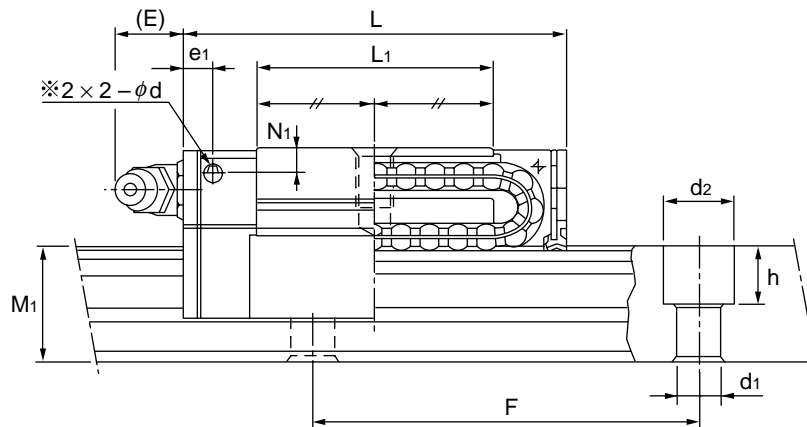

Unit; mm

Grease fitting	LM rail dimensions					Basic load rating		Mass	
	Width W_1 ± 0.05	W_2	Height M_1	Pitch F	$d_1 \times d_2 \times h$	C kN	C_0 kN	LM block kg	LM rail kg/m
PB1021B	15	9.5	12.5	60	4.5×7.5×5.3	9.10	9.7	0.08	1.2
B-M6F	20	11	15.5	60	6×9.5×8.5	13.4	14.4	0.14	2.1
B-M6F	23	12.5	18	60	7×11×9	21.7	22.5	0.23	2.7

● See page 12 for the standard LM rail lengths.

Note : Holes on the sides of the LM block for lubrication nipples are not made all the way through to prevent foreign materials from entering. Please contact THK when using lubrication nipples.

Type SSR-XTB

Standard type

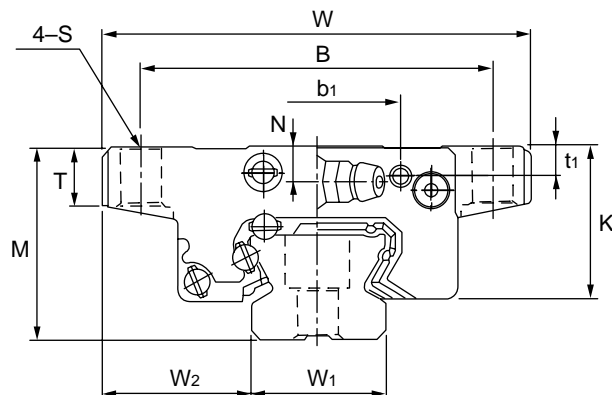

Model number	Outline dimensions			LM block dimensions												
	Height M	Width W	Length L	B	C	S	L ₁	T	K	N	E	N ₁	e ₁	b ₁	t ₁	d
SSR 15 XTBY	24	52	57	41	26	4.5	39.9	7	20	4.5	5.5	2.7	4	20.5	4.7	3
SSR 20 XTB	28	59	66.5	49	32	5.5	46.6	9	22	5.5	12	2.8	4.8	25	4.2	3
SSR 25 XTBY	33	73	83	60	35	7	59.8	10	26.2	6	12	3.3	4.6	29	5	3

Note : ●See page 7 for static permissible moment MA, MB, Mc.

Model number coding

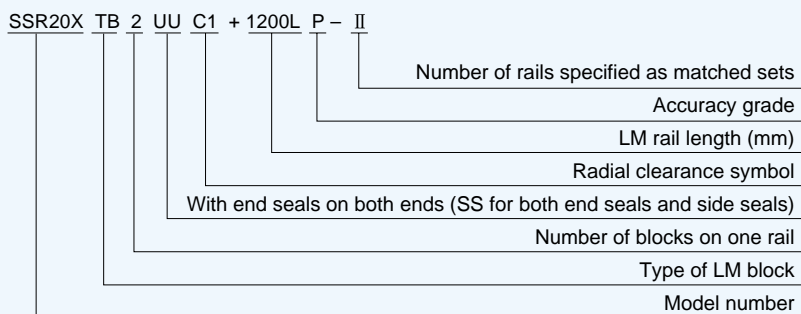

Note : This model number is for one rail unit on a one set basis.

(When two rails are to be specified as matched sets, at least two rail and block assemblies are necessary.)

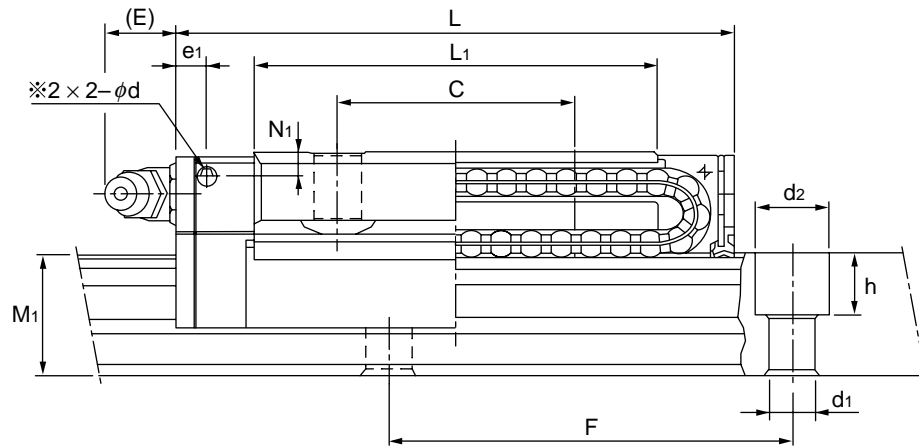

Unit: mm

Grease fitting	LM rail dimensions					Basic load rating		Mass	
	Width W_1 ± 0.05	W_2	Height M_1	Pitch F	$d_1 \times d_2 \times h$	C kN	C_0 kN	LM block kg	LM rail kg/m
PB1021B	15	18.5	12.5	60	4.5×7.5×5.3	14.7	16.5	0.19	1.2
B-M6F	20	19.5	15.5	60	6×9.5×8.5	19.6	23.4	0.31	2.1
B-M6F	23	25	18	60	7×11×9	31.5	36.4	0.53	2.7

● See page 12 for the standard LM rail lengths.

Note : Holes on the sides of the LM block for lubrication nipples are not made all the way through to prevent foreign materials from entering. Please contact THK when using lubrication nipples.

THK Radial type LM Guide® with Caged Ball™ Technology

SSR

Notes on use

*Precautions in handling the LM block

The LM block includes precision mold resin. When it is dropped or struck, it may be damaged. Please take great care in handling the LM block.

*Using holes on the sides of the LM block for lubrication nipples

When it is necessary to use holes on the sides of the LM block for attachment of lubrication nipples, please contact THK. THK will install nipples on the LM block. (Holes are not made all the way through to prevent foreign materials from entering.)

These holes are for lubrication nipples only. Use of these holes for other purpose may break end plate.

*Reinstalling the LM block

When the LM block is removed from the LM rail and then reinstalled, please insert it very carefully and correctly.

**For reinstallation, we recommend that a special insertion jig is to be used. Please contact THK upon the use of jig.

*Coolant

When the LM block is used in an environment in which some coolant may enter the LM block, some types of coolant may adversely affect the functions of the LM block. Please contact THK when selecting a coolant.

*Operating temperature range

The LM block is made from special resin. Do not use it above 80°C.

*Lubrication

Ordinary grease may not be utilized when the system is used in a special environment such as an area subject to extremes of temperature or continuous vibration, a clean room, or a vacuum environment. If the system is to be used in a special environment, please contact THK.

*All rights reserved.

*Specifications are subject to change without notice.

THK THK CO., LTD.

HEAD OFFICE 3-11-6, NISHI-GOTANDA, SHINAGAWA-KU, TOKYO 141-8503 JAPAN
INTERNATIONAL SALES DEPARTMENT PHONE:(03)5434-0351 FAX:(03)5434-0353

U. S. A.

CHICAGO

PHONE:(847)310-1111 FAX:(847)310-1182

NEW JERSEY

PHONE:(201)529-1950 FAX:(201)529-1962

LOS ANGELES

PHONE:(714)891-6752 FAX:(714)894-9315

SAN FRANCISCO

PHONE:(925)455-8948 FAX:(925)455-8965

ATLANTA

PHONE:(770)840-7990 FAX:(770)840-7897

DETROIT

PHONE:(248)858-9330 FAX:(248)858-9455

BOSTON

PHONE:(781)575-1151 FAX:(781)575-9295

INDIANAPOLIS

PHONE:(317)243-3496 FAX:(317)243-3499

MINNEAPOLIS

PHONE:(612)953-4442 FAX:(612)953-4441

CANADA (TORONTO)

PHONE:(905)712-2922 FAX:(905)712-2925

BRASIL (SÃO PAULO)

PHONE:(011)3924-0911 FAX:(011)3924-0900

GERMANY

DÜSSELDORF

PHONE:(02102)74250 FAX:(02102)7425299

STUTTGART

PHONE:(07141)2757-0 FAX:(07141)2757-90

U.K. (MILTON KEYNES)

PHONE:(01908)222159 FAX:(01908)222161

FRANCE (LYON)

PHONE:(0437)49.14.00 FAX:(0437)49.14.01

ITALY (MILAN)

PHONE:(039)2842079 FAX:(039)2842527

SWEDEN (STOCKHOLM)

PHONE:(08)4457630 FAX:(08)4457639

AUSTRIA (LINZ)

PHONE:(07229)51400 FAX:(07229)51400-79

SPAIN (BARCELONA)

PHONE:(093)652-5740 FAX:(093)652-5746

PGM BALLSCREWS LIMITED (COVENTRY)

PHONE:(02476)841900 FAX:(02476)611032

PGM BALLSCREWS IRELAND LIMITED (DUBLIN)

PHONE:(01)4628101 FAX:(01)4629080

TAIWAN

TAIPEI

PHONE:(02)2585-8554 FAX:(02)2585-8495

TAICHUNG

PHONE:(04)2359-1505 FAX:(04)2359-1506

CHINA

BEIJING

PHONE:(10)6590-3557 FAX:(10)6590-3557

HONG KONG

PHONE:23761091, 23761252 FAX:23760749

MALAYSIA (KUALA LUMPUR)

PHONE:(03)987-1137 FAX:(03)987-8071

INDIA (BANGALORE)

PHONE:(080)330-1524 FAX:(080)330-1524

KOREA (SEOUL)

PHONE:(02)3463-0351 FAX:(02)3017-0351