



Compliant with  
New Accuracy Standards

# Caged Ball LM Guide

Ball Cage Effect  
Lightweight, Compact Type

# SRS

**New Size Available: SRS5 Series**

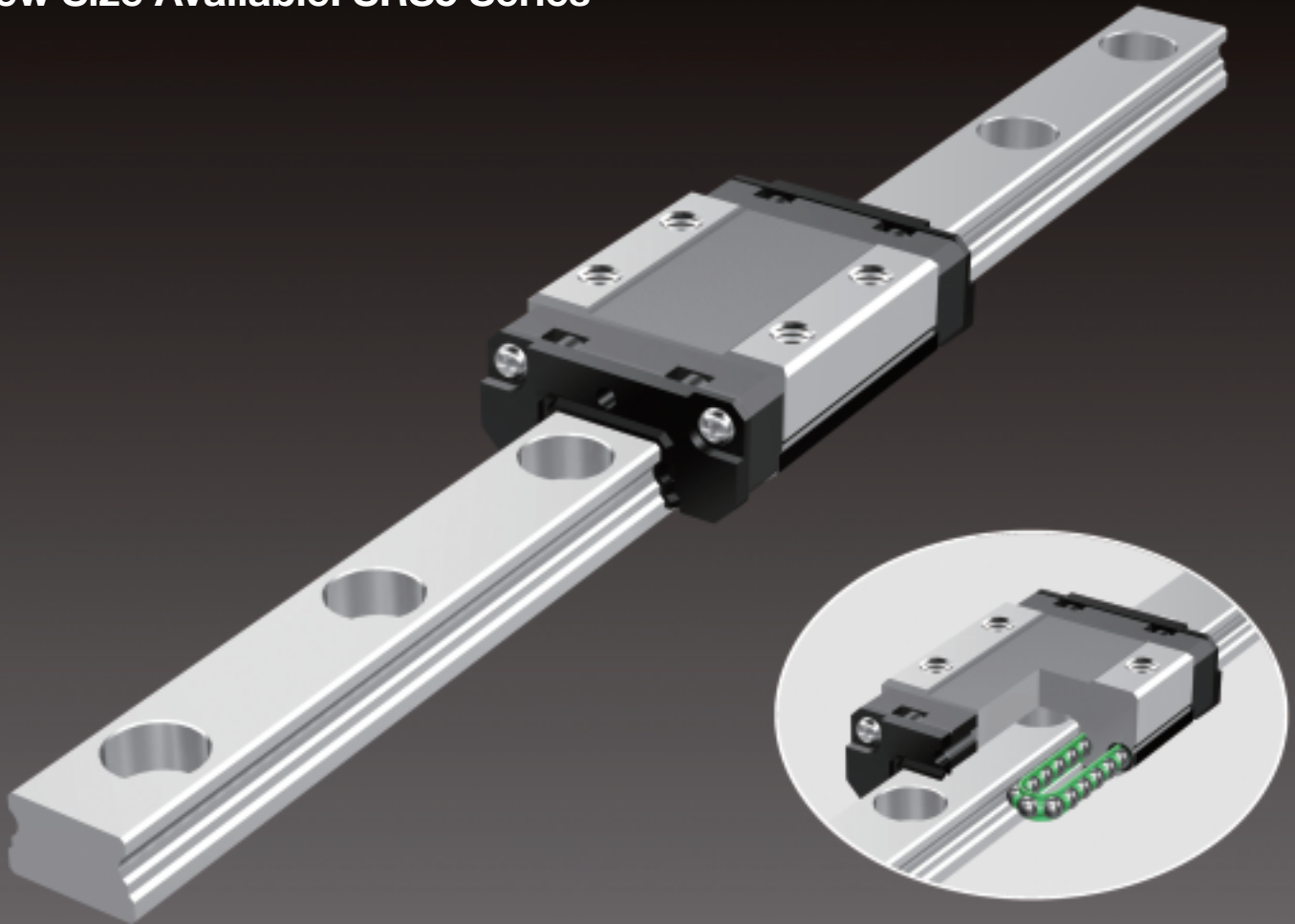

# Ball Cage Effect

The early forms of ball bearings were full-ball types without ball cages. Friction between balls caused loud noise, made high-speed rotation impossible and shortened the service life. Twenty years later, a Caged Ball design was developed for ball bearings. The new design enabled high-speed rotation at a low noise level, and extended the service life despite the reduced number of balls used. It marked a major development in the history of ball bearings.

Similarly, the quality of needle bearings was significantly improved by the caged needle structure. With cage-less, full-ball types of ball bearings, balls make metallic contact with one another and produce loud noise. In addition, they rotate in opposite directions, causing the sliding contact between two adjacent balls to occur at a speed twice the ball-spinning rate. It results in severe wear and shortens the service life.

In addition, without a cage, balls make point contact to increase bearing stress, thus facilitating breakage of the oil film. In contrast, each caged ball contacts the cage over a wide area. Therefore, the oil film does not break, the noise level is low and balls can rotate at a high speed, resulting in a long service life.

- Long Service Life and Long-term Maintenance-free Operation
- Superbly High Speed
- Low Noise, Acceptable Running Sound
- Smooth Motion
- Low Dust Generation

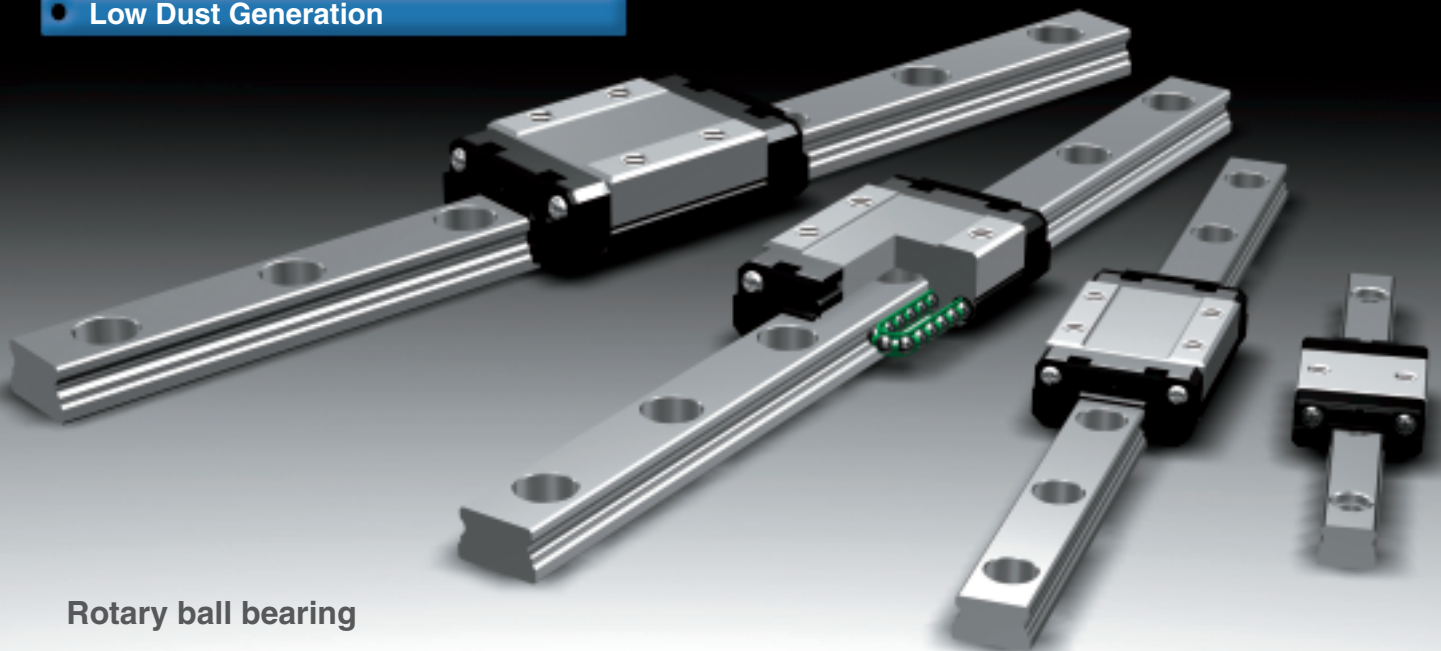

## Rotary ball bearing

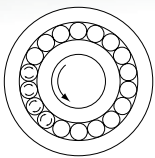

### Conventional structure

- Adjacent balls contact each other at a point. As a result, contact stress is high and the oil film breaks due to friction.
- The service life becomes shorter.

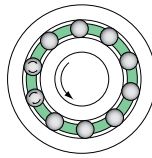

### Caged Ball structure

- The service life is prolonged due to the elimination of wear caused by friction between balls.
- The absence of friction between balls results in reduced heat generation during high-speed rotation.
- The absence of friction between balls eliminates collision noise of the balls.
- The even spacing of the balls enables them to move smoothly.
- Retention of lubricant in the ball cage ensures a long service life.

## Caged Ball LM Guide

With the Caged Ball LM Guide, the use of a ball cage allows lines of evenly spaced balls to circulate, thus to eliminating friction between the balls. In addition, grease held in a space between the ball circulation path and the ball cage (grease pocket) is applied on the contact surface between each ball and the ball cage as the ball rotates, forming an oil film on the ball surface. This minimizes the risk of oil-film break.

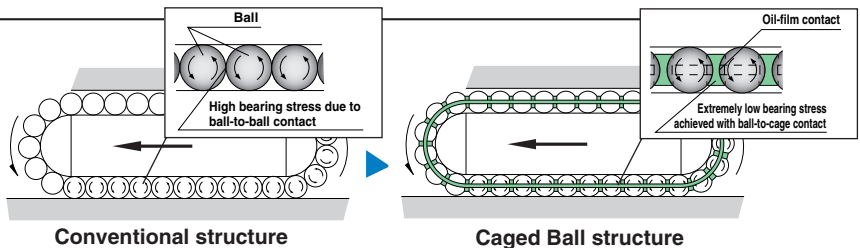

# Lightweight, Compact Type Caged Ball LM Guide

# SRS

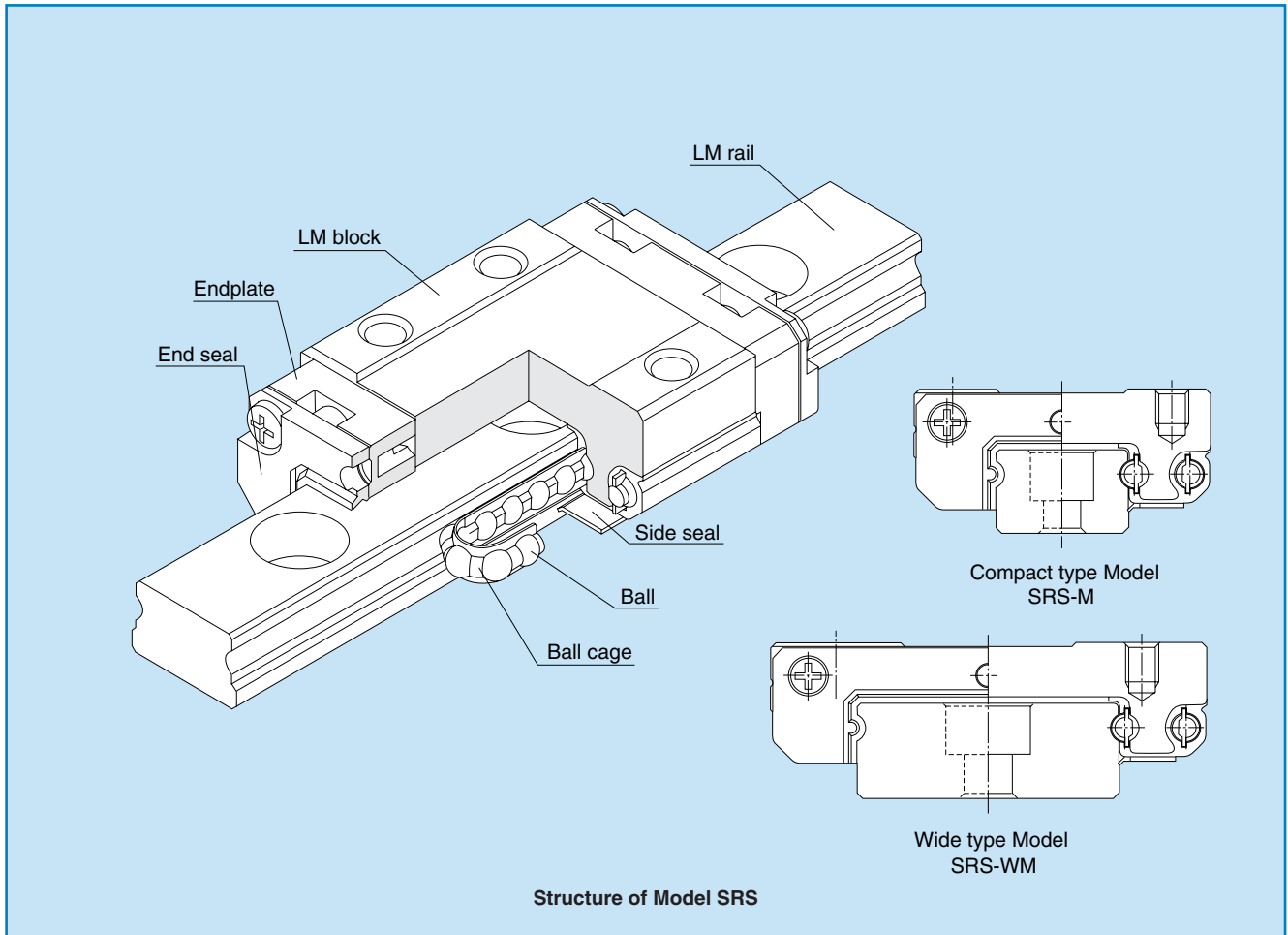

Caged Ball LM Guide model SRS has a structure where two raceways are incorporated into the compact body, enabling the model to receive loads in all directions, and to be used in locations where a moment is applied with a single rail. In addition, use of ball cages eliminates friction between balls, thus achieving high speed, low noise, acceptable running sound, long service life, and long-term maintenance-free operation.

## ● Low dust generation, anticorrosion

Use of ball cages eliminates friction between balls and retains lubricant, thus achieving low dust generation. In addition, the LM block and LM rail use stainless steel, which is highly resistant to corrosion.

## ● Compact

Since SRS has a compact structure where the rail cross section is designed to be low and that contains only two rows of balls, it can be installed in space-saving locations.

## ● Lightweight

Since part of the LM block (e.g., around the ball relief hole) is made of resin and formed through insert molding, SRS is a lightweight, low inertia type of LM Guide.



Model SRS WM

Model SRS M

# SRS Outline

## Model SRS - Product Overview

The most compact type among the Caged Ball LM Guide series

Lightweight, low-inertia structure

**Major applications** Semiconductor manufacturing machine / optical stage / medical equipment / IC bonder, etc.

### Model SRS5M

The smallest model of Caged Ball LM Guide. It is dimensionally (mounting) interchangeable with model RSR5M.

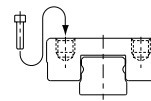
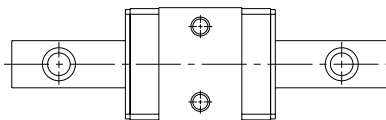

### Model SRS5WM

This model has a larger overall LM block length (L), width (W), rated load and permissible moment than model SRS5M. It is dimensionally (mounting) interchangeable with RSR5WM.

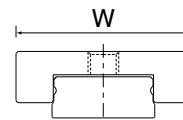
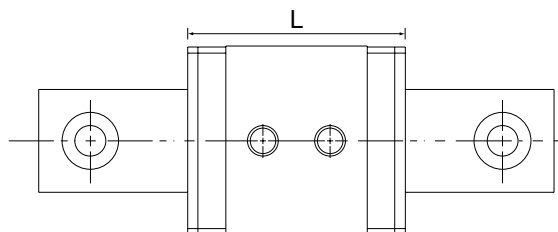

## Model SRS-M

### Standard type

A standard type of SRS.

- SRS 7M    ● SRS 15M
- SRS 9M    ● SRS 20M
- SRS 12M   ● SRS 25M

**Note:** Full-ball type (with no ball cage) for models SRS-M/WM is also available. If desiring the full-ball type, specify "SRS-G" type when making an order. However, since SRS-G type does not have a ball cage, its dynamic load rating is smaller than models SRS-M/WM.

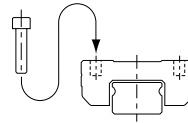
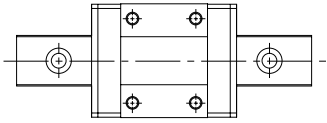

## Model SRS-WM

### Wide type

It has a longer overall LM block length (L), a greater width and a larger rated load and permissible moment than SRS-M.

- SRS 7WM    ● SRS 15WM
- SRS 9WM
- SRS 12WM

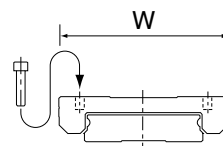
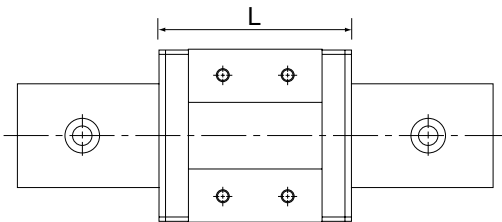

## Model SRS-N

### Long type

This model has a larger overall LM block length (L), rated load and permissible moment than model SRS-M.

- SRS 9N
- SRS 12N
- SRS 15N

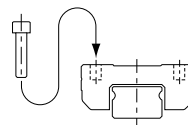
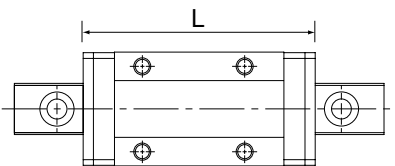

## Model SRS-WN

### Wide, long type

This model has a larger overall LM block length (L), rated load and permissible moment than model SRS-WM.

- SRS 9WN
- SRS 12WN
- SRS 15WN

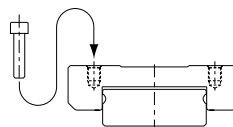
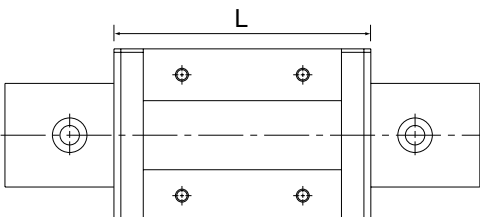

**\*1: Dimensional table for model SRS**

Model SRS5M/5WM  
→ pages 11-

Model SRS-M/N  
→ pages 13-

Model SRS-WM/WN  
→ pages 15-

## Rated Loads in All Directions

**Model SRS is capable of receiving loads in all four directions: radial, reverse-radial and lateral directions.**

Its basic dynamic load rating is represented by the symbol in the radial direction indicated in the figure on the right, and the actual value is provided in the dimensional table\*1 for model SRS. The values in the reverse-radial and lateral directions are obtained from table 1.

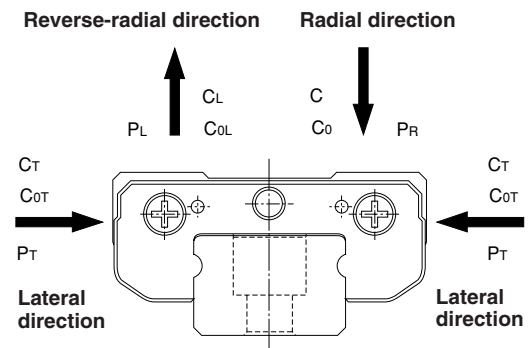

Rated Loads of Model SRS in All Directions

Direction	Basic dynamic load rating	Basic static load rating
Radial direction	C	C <sub>0</sub>
Reverse-radial direction	C <sub>L</sub> =C	C <sub>0L</sub> =C <sub>0</sub>
Lateral direction 1 (5M/5WM/7M/7WM/9M/9N/9WM/9WN/20M)	C <sub>T</sub> =1.19C	C <sub>0T</sub> =1.19C <sub>0</sub>
Lateral direction 2 (12M/12N/12WM/12WN/15M/15N/15WM/15WN/25M)	C <sub>T</sub> =C	C <sub>0T</sub> =C <sub>0</sub>

## Equivalent Load

**When the LM block of model SRS receives a radial load and a lateral load, or a reverse-radial load and a lateral load, simultaneously, the equivalent load is obtained from the equation below.**

$$P_E = X \cdot P_R (P_L) + Y \cdot P_T$$

where

- P<sub>E</sub> :Equivalent load [N]
- P<sub>R</sub> :Radial load [N]
- P<sub>L</sub> :Reverse-radial load [N]
- P<sub>T</sub> :Lateral load [N]
- X, Y:Equivalent factor (see the table below)

Equivalent Factor of Model SRS

Equivalent load P <sub>E</sub>	Model No.	X	Y
Radial and reverse-radial directions	5M/5WM/7M/7WM/9M/9N/9WM/9WN/20M	1	0.839
	12M/12N/12WM/12WN/15M/15N/15WM/15WN/25M	1	1
Lateral direction	5M/5WM/7M/7WM/9M/9N/9WM/9WN/20M	1.192	1
	12M/12N/12WM/12WN/15M/15N/15WM/15WN/25M	1	1

## Service life

The service life of an LM Guide is subject to variations even under the same operational conditions. Therefore, it is necessary to use the rated life defined below as a reference value for obtaining the service life of the LM Guide.

### Rated life

The rated life means the total travel distance that 90% of a group of units of the same LM Guide model can achieve without flaking (scale-like exfoliation on the metal surface) after individually running under the same conditions.

### Service life time

Once the rated life (L) has been obtained, the service life time can be obtained using the equation on the right if the stroke length and the number of reciprocations are constant.

$$L = \left( \frac{f_H \cdot f_T \cdot f_C}{f_W} \cdot \frac{C}{P_C} \right)^3 \times 50$$

L	: Rated life	[km]
C	: Basic dynamic load rating*	[N]
P <sub>C</sub>	: Calculated load	[N]
f <sub>H</sub>	: Hardness factor	(see Fig. 1)
f <sub>T</sub>	: Temperature factor	
f <sub>C</sub>	: Contact factor	(see Table 1)
f <sub>W</sub>	: Load factor	(see Table 2)

$$L_h = \frac{L \times 10^6}{2 \times \ell_s \times n_1 \times 60}$$

L <sub>h</sub>	: Service life time	[h]
ℓ <sub>s</sub>	: Stroke length	[mm]
n <sub>1</sub>	: No. of reciprocations per min	[min <sup>-1</sup> ]

\*1: Basic dynamic load rating (C)

It refers to a load with a constant magnitude and direction under which the rated life (L) of a group of identical LM Guide units independently operating is 50 km.

#### f<sub>H</sub> : Hardness factor

To ensure the achievement of the optimum load capacity of the LM Guide, the raceway hardness must be between 58 and 64 HRC. At hardness below this range, the basic dynamic and static load ratings decrease. Therefore, the rating values must be multiplied by the respective hardness factors (f<sub>H</sub>). Since the LM Guide has sufficient hardness, the f<sub>H</sub> value for the LM Guide is normally 1.0 unless otherwise specified.

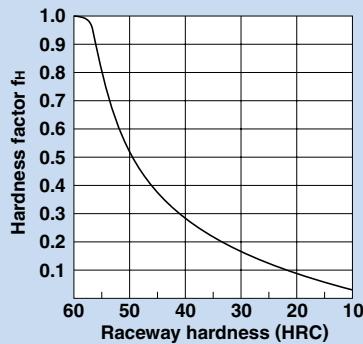

Fig. 1

#### f<sub>C</sub> : Contact factor

When multiple LM blocks are used in close contact with each other, it is difficult to achieve uniform load distribution due to moment loads and mounting-surface accuracy. When using multiple blocks in close contact with each other, multiply the basic load rating (C or C<sub>0</sub>) by the corresponding contact factor indicated in Table 1.

Note: When uneven load distribution is expected in a large machine, consider using a contact factor from Table 1.

Table 1 Contact Factor (f<sub>C</sub>)

Number of blocks used in close contact	Contact factor f <sub>C</sub>
2	0.81
3	0.72
4	0.66
5	0.61
6 or more	0.6
Normal use	1

#### f<sub>T</sub> : Temperature factor

Since the service temperature of Caged Ball LM Guides is normally 80°C or below, the f<sub>T</sub> value is 1.0.

#### f<sub>W</sub> : Load factor

In general, reciprocating machines tend to produce vibrations or impact during operation. It is especially difficult to accurately determine all vibrations generated during high-speed operation and impacts produced each time the machine starts and stops. Therefore, where the effects of speed and vibration are estimated to be significant, divide the basic dynamic load rating (C) by a load factor selected from Table 2, which contains empirically obtained data.

Table 2 Load Factor (f<sub>W</sub>)

Vibration/impact	Speed (V)	f <sub>W</sub>
Faint	Very slow V ≤ 0.25m/s	1 to 1.2
Weak	Slow 0.25 < V ≤ 1m/s	1.2 to 1.5
Moderate	Medium 1 < V ≤ 2m/s	1.5 to 2
Strong	Fast V > 2m/s	2 to 3.5

**\*1: Preload**

Preload is an internal load applied to the rolling elements (balls) of an LM block in advance in order to increase its rigidity.

The clearance of all model SRS units is adjusted to the designated value before being shipped. Therefore, it is unnecessary to adjust the preload.

## Radial Clearance Standard

Since the radial clearance of an LM Guide greatly affects the running accuracy, load carrying capacity and rigidity of the LM Guide, it is important to select an appropriate clearance according to the application.

In general, selecting a negative clearance (i.e., a preload\*1 is applied) while taking into account possible vibrations and impact generated from reciprocating motion favorably affects the service life and the accuracy.

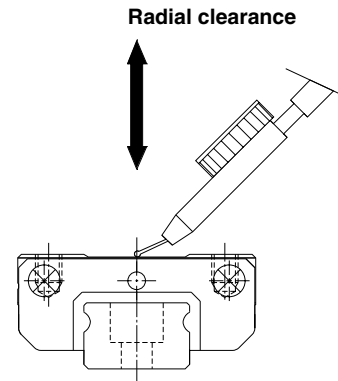
Unit:  $\mu\text{m}$ 

Model No.	Indication symbol	Normal	Light preload
		No symbol	C1
5M		0 to +1.5	- 1 to 0
5WM		0 to +1.5	- 1 to 0
7M		-2 to +2	- 3 to 0
7WM		-2 to +2	- 3 to 0
9M/N		-2 to +2	- 4 to 0
9WM/WN		-2 to +2	- 4 to 0
12M/N		-3 to +3	- 6 to 0
12WM/WN		-3 to +3	- 6 to 0
15M/N		-5 to +5	-10 to 0
15WM/WN		-5 to +5	-10 to 0
20M		-5 to +5	-10 to 0
25M		-7 to +7	-14 to 0

# Accuracy Standard

The accuracy of model SRS is specified in terms of running parallelism (\*1), dimensional tolerance for height and width, and height and width difference between a pair (\*2,\*3) when two or more LM blocks are used on one rail or when two or more rails are mounted on the same plane.

The accuracy of model SRS is classified into normal grade (no symbol), high grade (H) and precision grade (P) as indicated in the table below.

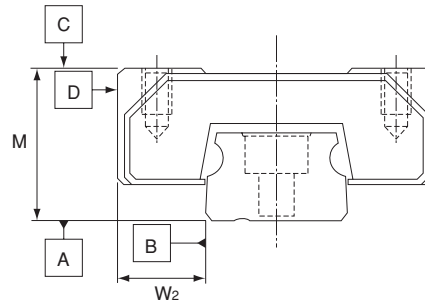

**\*1: Running parallelism**

It refers to the parallelism error between the LM block and the LM rail datum plane when the LM block travels the whole length of the LM rail with the LM rail secured on the reference datum plane using bolts.

**\*2: Difference in height M**

It indicates the difference between the minimum and maximum values of height (M) of each of the LM blocks used on the same plane in combination.

**\*3: Difference in width W<sub>2</sub>**

It indicates the difference between the minimum and maximum values of the width (W<sub>2</sub>) between each of the LM blocks, mounted on one LM rail in combination, and the LM rail.

## Model SRS5

Unit: mm

Model No.	Accuracy standard	Normal grade	High-accuracy grade	Precision grade
	Item	No symbol	H	P
5	Dimensional tolerance for height M	±0.03	—	±0.015
	Difference in height M	0.015	—	0.005
	Dimensional tolerance for width W <sub>2</sub>	±0.03	—	±0.015
	Difference in width W <sub>2</sub>	0.015	—	0.005
	Running parallelism of surface C against surface A	as shown in the table on the right		
	Running parallelism of surface D against surface B	as shown in the table on the right		

Note: "—" indicates not available.

LM Rail Length and Running Parallelism by Accuracy of model SRS

LM rail length[mm]		Running Parallelism Values[ μ m]	
Above	Or less	Normal grade	Precision grade
—	25	2.5	1.5
25	50	3.5	2
50	100	5.5	3
100	150	7	4
150	200	8.4	5

## Model SRS7/9/12/15/20/25

Unit: mm

Model No.	Accuracy standard	Normal grade	High-accuracy grade	Precision grade
	Item	No symbol	H	P
7	Dimensional tolerance for height M	±0.04	±0.02	±0.01
	Difference in height M	0.03	0.015	0.007
9	Dimensional tolerance for width W <sub>2</sub>	±0.04	±0.025	±0.015
12	Difference in width W <sub>2</sub>	0.03	0.02	0.01
15	Running parallelism of surface C against surface A	as shown in the table on the right		
20	Running parallelism of surface D against surface B	as shown in the table on the right		
25				

LM Rail Length and Running Parallelism by Accuracy of model SRS

LM rail length[mm]		Running Parallelism Values[ μ m]		
Above	Or less	Normal grade	High-accuracy grade	Precision grade
—	40	8	4	1
40	70	10	4	1
70	100	11	4	2
100	130	12	5	2
130	160	13	6	2
160	190	14	7	2
190	220	15	7	3
220	250	16	8	3
250	280	17	8	3
280	310	17	9	3
310	340	18	9	3
340	370	18	10	3
370	400	19	10	3
400	430	20	11	4
430	460	20	12	4
460	520	21	12	4
520	550	22	12	4
550	640	22	13	4
640	670	23	13	4
670	700	23	13	5
700	820	23	14	5
820	850	24	14	5
850	970	24	15	5
970	1030	25	16	5
1030	1150	25	16	6
1150	1330	26	17	6
1330	1420	27	18	6
1420	1510	27	18	7
1510	1800	28	19	7

## Shoulder Height of the Mounting Base and the Corner Radius

Normally, the mounting base for the LM rail and the LM block has a datum plane on the side face of the shoulder of the base in order to allow easy installation and highly accurate positioning.

The corner of the mounting shoulder must be machined to have a recess, or machined to be smaller than the corner radius "r," to prevent interference with the chamfer of the LM rail or the LM block.

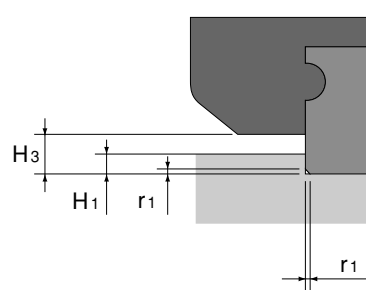

**Shoulder for the LM rail**

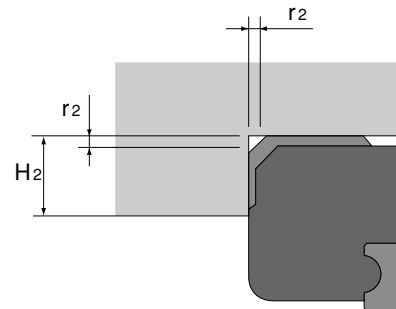

**Shoulder for the LM block**

Unit: mm

Model No.	Corner radius for the LM rail $r_1(\text{max})$	Corner radius for the LM block $r_2(\text{max})$	Shoulder height for the LM rail $H_1$	Shoulder height for the LM block $H_2$	$H_3$
5M	0.1	0.3	1.2	2	1.5
5WM	0.1	0.2	1.2	2.5	1.5
7M	0.1	0.2	0.9	3.3	1.3
7WM	0.1	0.1	1.4	3.8	1.8
9M/N	0.1	0.3	0.5	4.9	0.9
9WM/WN	0.1	0.5	2.5	4.9	2.9
12M/N	0.3	0.2	1.5	5.7	2
12WM/WN	0.3	0.3	2.5	5.7	3
15M/N	0.3	0.4	2.2	6.5	2.7
15WM/WN	0.3	0.3	2.2	6.5	2.7
20M	0.3	0.5	3	8.7	3.4
25M	0.5	0.5	4.5	10.5	5

## Error Allowance in the Parallelism Between Two Rails

The table shows error allowances in parallelism (P) between two rails that will not affect the service life in normal operation.

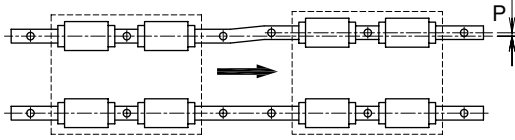

Unit:  $\mu\text{m}$

Model No.	Clearance C1	Normal clearance
5M	—	2
5WM	—	2
7M	—	3
7WM	—	3
9M/N	3	4
9WM/WN	3	4
12M/N	5	9
12WM/WN	5	9
15M/N	6	10
15WM/WN	6	10
20M	8	13
25M	10	15

## Error Allowance in Vertical Level Between Two Rails

The values in the table each indicate the error allowance (S) in vertical level between two rails per 200 mm of the axis-to-axis distance, and are proportional to the axis-to-axis distance.

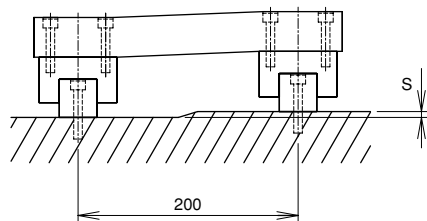

Unit:  $\mu\text{m}$

Model No.	Clearance C1	Normal clearance
5M	—	20
5WM	—	20
7M	—	25
7WM	—	25
9M/N	6	35
9WM/WN	6	35
12M/N	12	50
12WM/WN	12	50
15M/N	20	60
15WM/WN	20	60
20M	30	70
25M	40	80

## Flatness of the LM Rail and the LM Block Mounting Surface

The values in the table apply when the clearance is a normal clearance. If the clearance is clearance C1 and two rails are used in combination, we recommend using 50% or less of the value in the table.

Since SRS has Gothic-arch grooves, any accuracy error in the mounting surface may negatively affect the operation. Therefore, we recommend using SRS on a highly accurate mounting surface.

Unit: mm

Model No.	Flatness
5M	0.015/200
5WM	0.015/200
7M	0.025/200
7WM	0.025/200
9M/N	0.035/200
9WM/WN	0.035/200
12M/N	0.050/200
12WM/WN	0.050/200
15M/N	0.060/200
15WM/WN	0.060/200
20M	0.070/200
25M	0.070/200

# Model SRS5M/7M

## Dimensional Table for Model SRS5M/7M

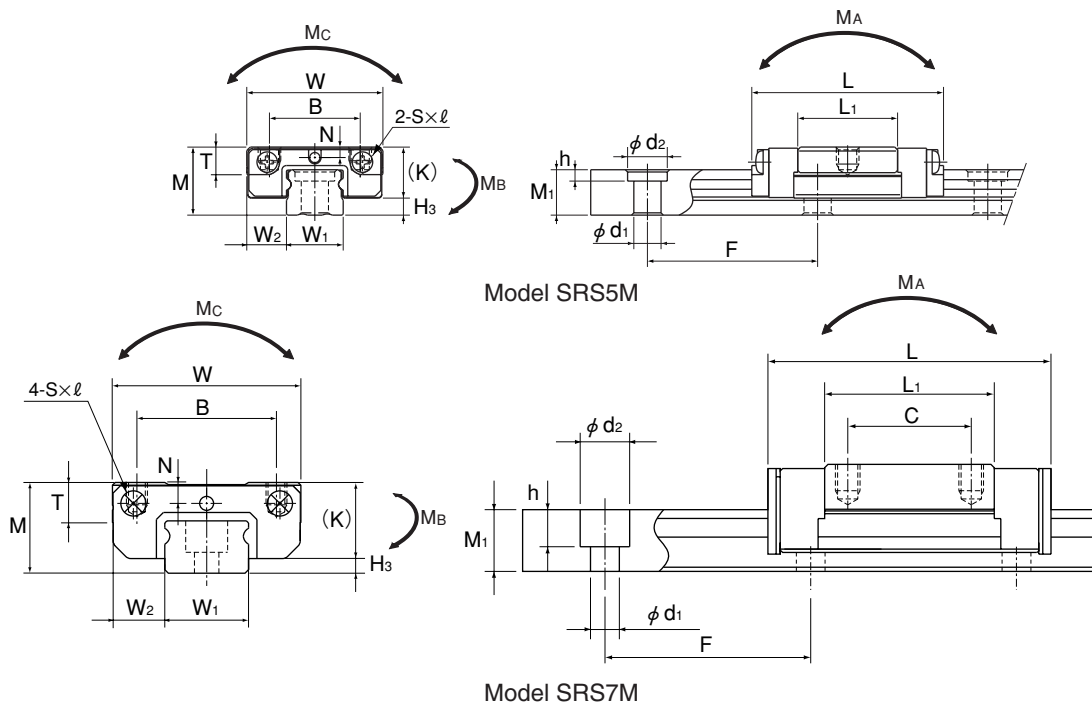

Unit: mm

Model No.	Outer dimensions			LM block dimensions							H <sub>3</sub>
	Height M	Width W	Length L	B	C	S × ℓ	L <sub>1</sub>	T	K	N	
<b>SRS 5M</b>	6	12	16.9	8	—	M2×1.5	8.8	1.7	4.5	0.93	1.5
<b>SRS 7M</b>	8	17	23.4	12	8	M2×2.3	13.4	3.3	6.7	1.6	1.3

Unit: mm

Model No.	LM rail dimensions					Length Max <sup>*1</sup>	Basic load rating		Static permissible moment [N·m] <sup>*2</sup>				Mass		
	Width W <sub>1</sub>	W <sub>2</sub>	Height M <sub>1</sub>	Pitch F	d × d <sub>2</sub> × h		C [N]	C <sub>0</sub> [N]	M <sub>A</sub> 1 block	M <sub>B</sub> 2 blocks in close contact	M <sub>C</sub> 1 block	LM block [kg]	LM rail [kg/m]		
<b>SRS 5M</b>	5 <sup>0</sup> <sub>-0.02</sub>	3.5	4	15	2.4×3.5×1	200	439	468	0.74	5.11	0.86	5.99	1.21	0.002	0.13
<b>SRS 7M</b>	7 <sup>0</sup> <sub>-0.02</sub>	5	4.7	15	2.4×4.2×2.3	300	1510	1290	3.09	17.2	3.69	17.3	5.02	0.009	0.25

**Note** Since the LM block, LM rails, and balls are stainless steel, this model is highly resistant to corrosion and the environment.

\*1 The maximum length under "Length" indicates the standard maximum length of an LM rail.

\*2 Static permissible moment: 1 block: static permissible moment value with 1 LM block

Double blocks: static permissible moment value with 2 blocks closely contacting with each other

● The following table shows a reference bolt-tightening torque for mounting the LM block of model SRS 5M/7M.

### Reference tightening torque

Model No.	Nominal model number of screw	Screw depth [mm]	Reference tightening torque [N·m] <sup>*</sup>
SRS 5M	M2	1.5	0.4
SRS 7M	M2	2.3	0.4

\* If the bolt is tightened with a torque exceeding the specified tightening torque, it may affect the accuracy. Be sure to tighten the bolt with a torque below the specified value.

### Example of model number coding

**2 SRS7M QZ UU C1 +100L P M- II**

1 2 3 4 5 6 7 8 9

1 No. of LM blocks used on the same rail 2 Model number 3 With QZ Lubricator (see page 21) 4 Dust prevention accessory symbol (see page 20) 5 Radial clearance symbol (see page 7) 6 LM rail length (in mm) 7 Accuracy symbol (see page 8) 8 LM rail is made of stainless steel 9 No. of rails used on the same plane

**Note** This model number indicates that an LM block and an LM rail constitute one set.

# Model SRS5WM/7WM

## Dimensional Table for Model SRS5WM/7WM

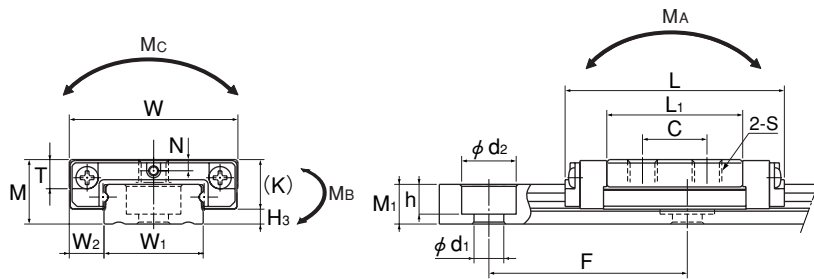

Model SRS5WM

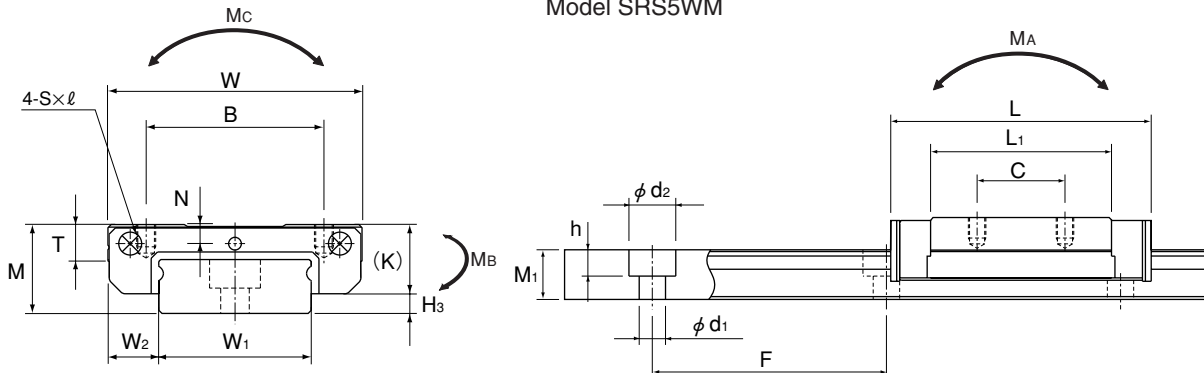

Model SRS7WM

Unit: mm

Model No.	Outer dimensions			LM block dimensions							
	Height M	Width W	Length L	B	C	S x l	L <sub>1</sub>	T	K	N	H <sub>3</sub>
<b>SRS 5WM</b>	6.5	17	22.1	—	6.5	M3通シ	13.7	2.7	5	1.1	1.5
<b>SRS 7WM</b>	9	25	31	19	10	M3×2.8	20.4	3.8	7.2	1.8	1.8

Unit: mm

Model No.	LM rail dimensions						Basic load rating		Static permissible moment [N·m] <sup>*2</sup>					Mass	
	Width W <sub>1</sub>	W <sub>2</sub>	Height M <sub>1</sub>	Pitch F	d <sub>1</sub> × d <sub>2</sub> × h	Length Max <sup>*1</sup>	C [N]	C <sub>0</sub> [N]	M <sub>A</sub>		M <sub>B</sub>		M <sub>C</sub>	LM block [kg]	LM rail [kg/m]
									1 block	2 blocks in close contact	1 block	2 blocks in close contact			
<b>SRS 5WM</b>	10 <sup>0</sup> <sub>-0.02</sub>	3.5	4	20	3×5.5×3	200	584	703	1.57	9.59	1.83	11.24	3.58	0.005	0.27
<b>SRS 7WM</b>	14 <sup>0</sup> <sub>-0.02</sub>	5.5	5.2	30	3.5×6×3.2	400	2010	1940	6.47	22.7	7.71	22.7	14.33	0.018	0.56

**Note** Since the LM block, LM rails, and balls are stainless steel, this model is highly resistant to corrosion and the environment.

\*1 The maximum length under "Length" indicates the standard maximum length of an LM rail.

\*2 Static permissible moment: 1 block: static permissible moment value with 1 LM block

Double blocks: static permissible moment value with 2 blocks closely contacting with each other

● The following table shows a reference bolt-tightening torque for mounting the LM block of model SRS 5WM/7WM.

### Reference tightening torque

Model No.	Nominal model number of screw	Screw depth [mm]	Reference tightening torque [N·m]*
SRS 5WM	M3	2.3	0.4
SRS 7WM	M3	2.8	0.4

\* If the bolt is tightened with a torque exceeding the specified tightening torque, it may affect the accuracy. Be sure to tighten the bolt with a torque below the specified value.

### Example of model number coding

**2 SRS7WM QZ UU C1 +200L P M- II**

1 2 3 4 5 6 7 8 9

1 No. of LM blocks used on the same rail 2 Model number 3 With QZ Lubricator (see page 21) 4 Dust prevention accessory symbol (see page 20) 5 Radial clearance symbol (see page 7) 6 LM rail length (in mm) 7 Accuracy symbol (see page 8) 8 LM rail is made of stainless steel 9 No. of rails used on the same plane

**Note** This model number indicates that an LM block and an LM rail constitute one set.

# Model SRS-M/SRS-N

## Dimensional Table for Model SRS-M/SRS-N

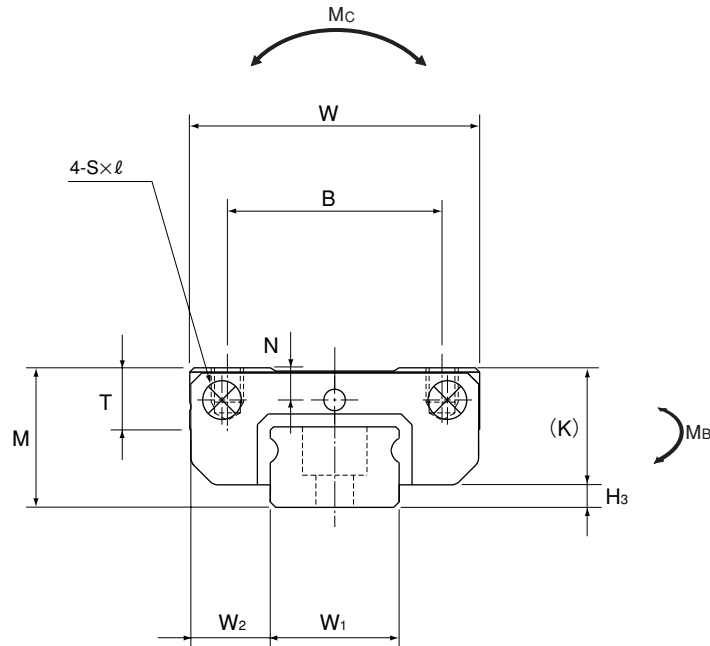

Model No.	Outer dimensions			LM block dimensions							
	Height M	Width W	Length L	B	C	SX l	L <sub>i</sub>	T	K	N	H <sub>s</sub>
<b>SRS 9M</b>	10	20	30.8	15	10	M3×2.8	19.8	4.9	9.1	2.4	0.9
<b>SRS 9N</b>	10	20	40.8	15	16	M3×2.8	29.8	4.9	9.1	2.4	0.9
<b>SRS 12M</b>	13	27	34.4	20	15	M3×3.2	20.6	5.7	11	3	2
<b>SRS 12N</b>	13	27	47.1	20	20	M3×3.2	33.3	5.7	11	3	2
<b>SRS 15M</b>	16	32	43	25	20	M3×3.5	25.7	6.5	13.3	3	2.7
<b>SRS 15N</b>	16	32	60.8	25	25	M3×3.5	43.5	6.5	13.3	3	2.7
<b>SRS 20M</b>	20	40	50	30	25	M4×6.0	34	9	16.6	4	3.4
<b>SRS 25M</b>	25	48	77	35	35	M6×7.0	56	11	20	5	5

**Note** Since the LM block, LM rails, and balls are stainless steel, this model is highly resistant to corrosion and the environment.

### ■ Example of model number coding

**2 SRS20M QZ UU C1 +220L P M- II**

1 2 3 4 5 6 7 8 9

1 No. of LM blocks used on the same rail 2 Model number 3 With QZ Lubricator (see page 21) 4 Dust prevention accessory symbol (see page 20) 5 Radial clearance symbol (see page 7) 6 LM rail length (in mm) 7 Accuracy symbol (see page 8) 8 LM rail is made of stainless steel 9 No. of rails used on the same plane

**Note** This model number indicates that an LM block and an LM rail constitute one set (i.e., the required number of sets when 2 rails are used in parallel is 2). Those models equipped with QZ Lubricator cannot have a grease nipple.

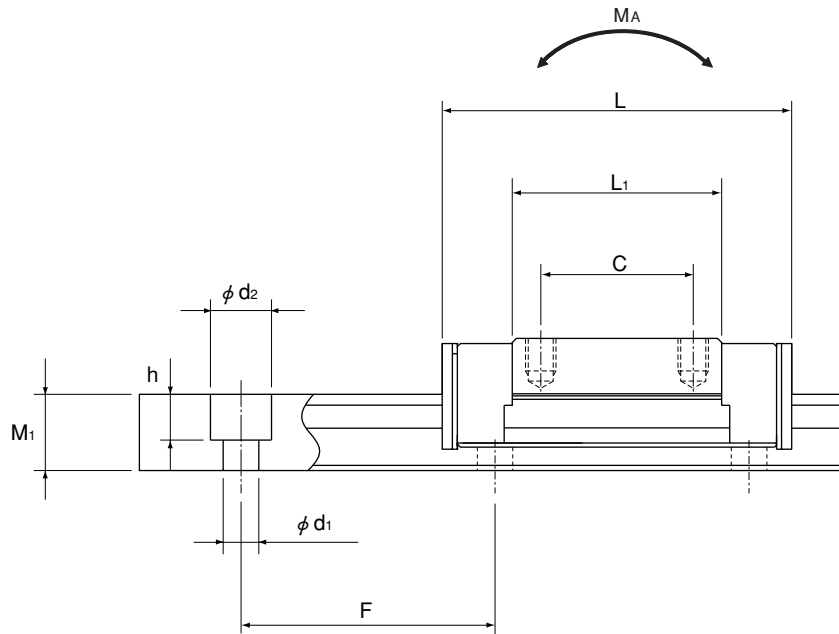

Unit: mm

	LM rail dimensions						Basic load rating		Static permissible moment [N-m]*2					Mass	
	Width	Height	Pitch	Length*1	C	C0	MA		MB		MC	LM block [kg]	LM rail [kg/m]		
	W1	W2	M1				F	d1x d2 x h	Max	[kN]	[kN]			1 block	2 blocks in close contact
9	0 -0.02	5.5	5.5	20	3.5x6x3.3	1000	2.69	2.31	7.82	43.9	9.03	50.8	10.6	0.016	0.32
9	0 -0.02	5.5	5.5	20	3.5x6x3.3	1000	3.48	3.34	15.5	81.4	17.9	94.3	15.3	0.027	0.32
12	0 -0.02	7.5	7.5	25	3.5x6x4.5	1340	4	3.53	12	78.5	12	78.5	23.1	0.027	0.65
12	0 -0.02	7.5	7.5	25	3.5x6x4.5	1340	5.82	5.3	28.4	151	28.4	151	34.7	0.049	0.65
15	0 -0.02	8.5	9.5	40	3.5x6x4.5	1430	6.66	5.7	26.2	154	26.2	154	40.4	0.047	0.96
15	0 -0.02	8.5	9.5	40	3.5x6x4.5	1430	9.71	8.55	59.7	312	59.7	312	60.7	0.095	0.96
20	0 -0.03	10	11	60	6x9.5x8	1800	7.75	9.77	54.3	296	62.4	341	104	0.11	1.68
23	0 -0.03	12.5	15	60	7x11x9	1800	16.5	20.2	177	932	177	932	248	0.24	2.6

**Note** If a grease nipple is required, indicate "with grease nipple" (available for models SRS 15M/15N/20M/25M).  
If a greasing hole is required, indicate "with greasing hole" (available for models SRS 9M/9N/12M/12N).

\*1 The maximum length under "Length" indicates the standard maximum length of an LM rail.  
\*2 Static permissible moment: 1 block: static permissible moment value with 1 LM block  
2 blocks: static permissible moment value with 2 blocks closely contacting with each other

**SRS-G Basic Load Ratings**

Model No.	Basic load rating	
	C [kN]	C0 [kN]
SRS 9GM	2.07	2.32
SRS 12GM	3.36	3.55
SRS 15GM	5.59	5.72
SRS 20GM	5.95	9.4
SRS 25GM	13.3	22.3

**Note** Full-ball type (with no ball cage) for model SRS-M is also available. If desiring the full-ball type, specify "SRS-G" type when making an order. However, since SRS-G type does not have a ball cage, its dynamic load rating is smaller than model SRS-M.

# Model SRS-WM/SRS-WN

## Dimensional Table for Model SRS-WM/SRS-WN

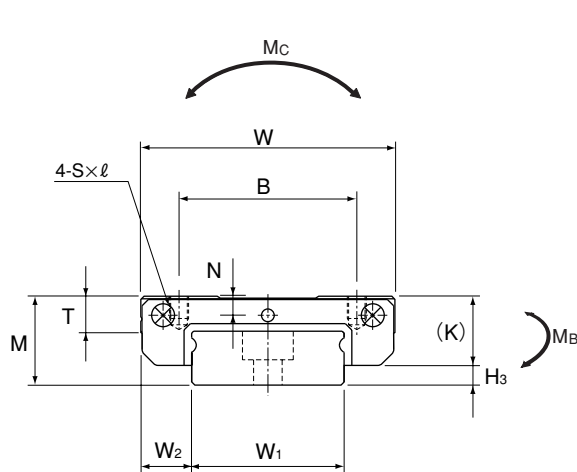

Models SRS9,12WM/WN

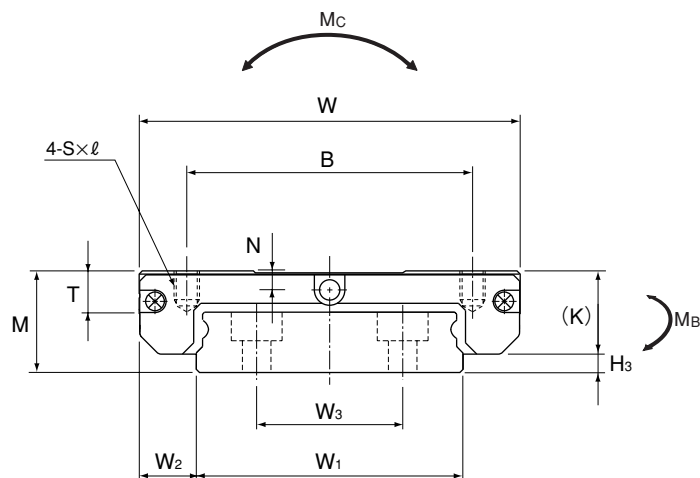

Model SRS15WM/WN

Model No.	Outer dimensions			LM block dimensions							H <sub>s</sub>
	Height M	Width W	Length L	B	C	SX ℓ	L <sub>1</sub>	T	K	N	
<b>SRS 9WM</b>	12	30	39	21	12	M3×2.8	27	4.9	9.1	2.3	2.9
<b>SRS 9WN</b>	12	30	50.7	23	24	M3×2.8	38.7	4.9	9.1	2.3	2.9
<b>SRS 12WM</b>	14	40	44.5	28	15	M3×3.5	30.9	5.7	11	3	3
<b>SRS 12WN</b>	14	40	59.5	28	28	M3×3.5	45.9	5.7	11	3	3
<b>SRS 15WM</b>	16	60	55.5	45	20	M4×4.5	38.9	6.5	13.3	3	2.7
<b>SRS 15WN</b>	16	60	74.5	45	35	M4×4.5	57.9	6.5	13.3	3	2.7

**Note** Since the LM block, LM rails, and balls are stainless steel, this model is highly resistant to corrosion and the environment.

### Example of model number coding

**2 SRS15WM QZ UU C1 +550L P M- II**

1 2 3 4 5 6 7 8 9

1 No. of LM blocks used on the same rail 2 Model number 3 With QZ Lubricator (see page 21) 4 Dust prevention accessory symbol (see page 20) 5 Radial clearance symbol (see page 7) 6 LM rail length (in mm) 7 Accuracy symbol (see page 8) 8 LM rail is made of stainless steel 9 No. of rails used on the same plane

**Note** This model number indicates that an LM block and an LM rail constitute one set (i.e., the required number of sets when 2 rails are used in parallel is 2). Those models equipped with QZ Lubricator cannot have a grease nipple.

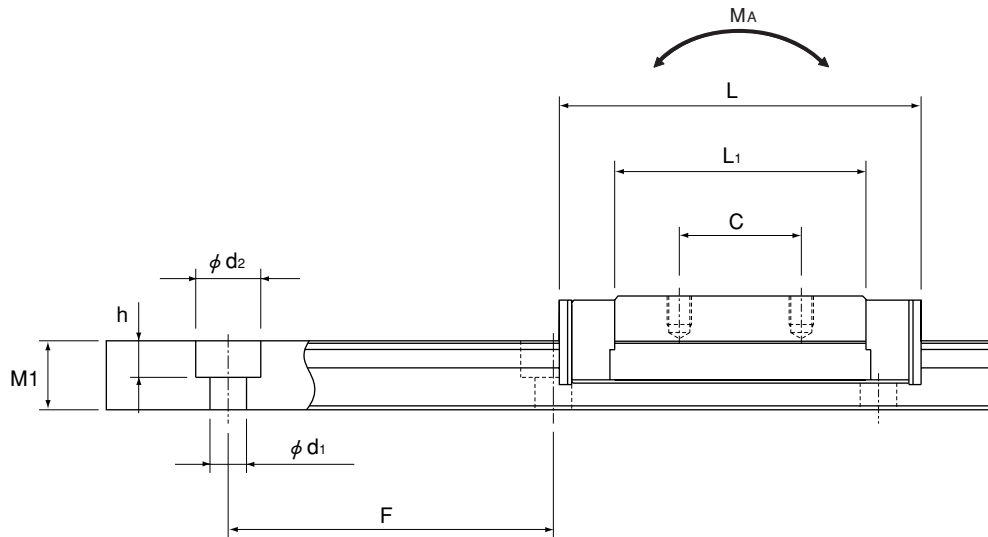

Unit: mm

	LM rail dimensions							Basic load rating		Static permissible moment [N-m] <sup>*2</sup>					Mass	
	Width			Height	Pitch		Length	C	C <sub>0</sub>	M <sub>a</sub>	M <sub>b</sub>	M <sub>c</sub>	LM block	LM rail		
	W <sub>1</sub>	W <sub>2</sub>	W <sub>3</sub>	M <sub>1</sub>	F	d <sub>1</sub> ×d <sub>2</sub> ×h	Max <sup>*1</sup>	[kN]	[kN]	1 block	2 blocks in close contact	1 block	2 blocks in close contact	1 block	[kg]	[kg/m]
	18 <sup>0</sup> <sub>-0.02</sub>	6	—	7.5	30	3.5×6×4.5	1000	3.29	3.34	14	78.6	16.2	91	31.5	0.031	1.01
	18 <sup>0</sup> <sub>-0.02</sub>	6	—	7.5	30	3.5×6×4.5	1000	4.2	4.37	25.1	130	29.1	151	41.3	0.049	1.01
	24 <sup>0</sup> <sub>-0.02</sub>	8	—	8.5	40	4.5×8×4.5	1430	5.48	5.3	26.4	143	26.4	143	66.5	0.055	1.52
	24 <sup>0</sup> <sub>-0.02</sub>	8	—	8.5	40	4.5×8×4.5	1430	7.13	7.07	49.2	249	49.2	249	88.7	0.091	1.52
	42 <sup>0</sup> <sub>-0.02</sub>	9	23	9.5	40	4.5×8×4.5	1800	9.12	8.55	51.2	290	51.2	290	176	0.13	2.87
	42 <sup>0</sup> <sub>-0.02</sub>	9	23	9.5	40	4.5×8×4.5	1800	12.4	12.1	106	532	106	532	250	0.201	2.87

**Note** If a grease nipple is required, indicate "with grease nipple" (available for models SRS 15WM/15WN).  
If a greasing hole is required, indicate "with greasing hole" (available for models SRS 9WM/9WN/12WM/12WN)

\*1 The maximum length under "Length" indicates the standard maximum length of an LM rail.

\*2 Static permissible moment: 1 block: static permissible moment value with 1 LM block

2 blocks: static permissible moment value with 2 blocks closely contacting with each other

### SRS-G Basic Load Ratings

Model No.	Basic load rating	
	C [kN]	C <sub>0</sub> [kN]
SRS 9WGM	2.67	3.35
SRS 12WGM	4.46	5.32
SRS 15WGM	7.43	8.59

**Note** Full-ball type (with no ball cage) for model SRS-WM is also available. If desiring the full-ball type, specify "SRS-G" type when making an order. However, since SRS-G type does not have a ball cage, its dynamic load rating is smaller than model SRS-WM.

# SRS-M/WM

## Standard Length and Maximum Length of the LM Rail

The table below shows the standard LM rail lengths and the maximum lengths of model SRS variations. If the maximum length of the desired LM rail exceeds them, connected rails will be used. Contact THK for details.

For the G dimension when a special length is required, we recommend selecting the corresponding G value from the table. The longer the G dimension is, the less stable the G area may become after installation, thus adversely affecting accuracy.

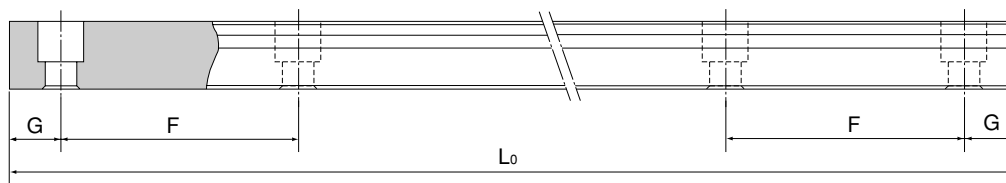

Table Standard Length and Maximum Length of the LM Rail for Model SRS

Unit: mm

Model No.	SRS 5M	SRS 5WM	SRS 7M	SRS 7WM	SRS 9M/N	SRS 9WM/WN	SRS 12M/N	SRS 12WM/WN	SRS 15M/N	SRS 15WM/WN	SRS 20M	SRS 25M
Standard LM rail length ( $L_0$ )	40	50	40	50	55	50	70	70	70	110	220	220
	55	70	55	80	75	80	95	110	110	150	280	280
	70	90	70	110	95	110	120	150	150	190	340	340
	100	110	85	140	115	140	145	190	190	230	460	460
	130	130	100	170	135	170	170	230	230	270	640	640
	160	150	115	200	155	200	195	270	270	310	880	880
			170	130	260	175	260	220	310	310	430	1000
				290	195	290	245	390	350	550		
					275	320	270	470	390	670		
					375		320	550	430	790		
							370		470			
							470		550			
							570		670			
								870				
Standard pitch F	15	20	15	30	20	30	25	40	40	40	60	60
G	5	5	5	10	7.5	10	10	15	15	15	20	20
Max length	200	200	300	400	1000	1000	1340	1430	1430	1800	1800	1800

Note 1: The maximum length varies with accuracy grades. Contact THK for details.

Note 2: If connected rails are not allowed and a greater length than the maximum values above is required, contact THK.

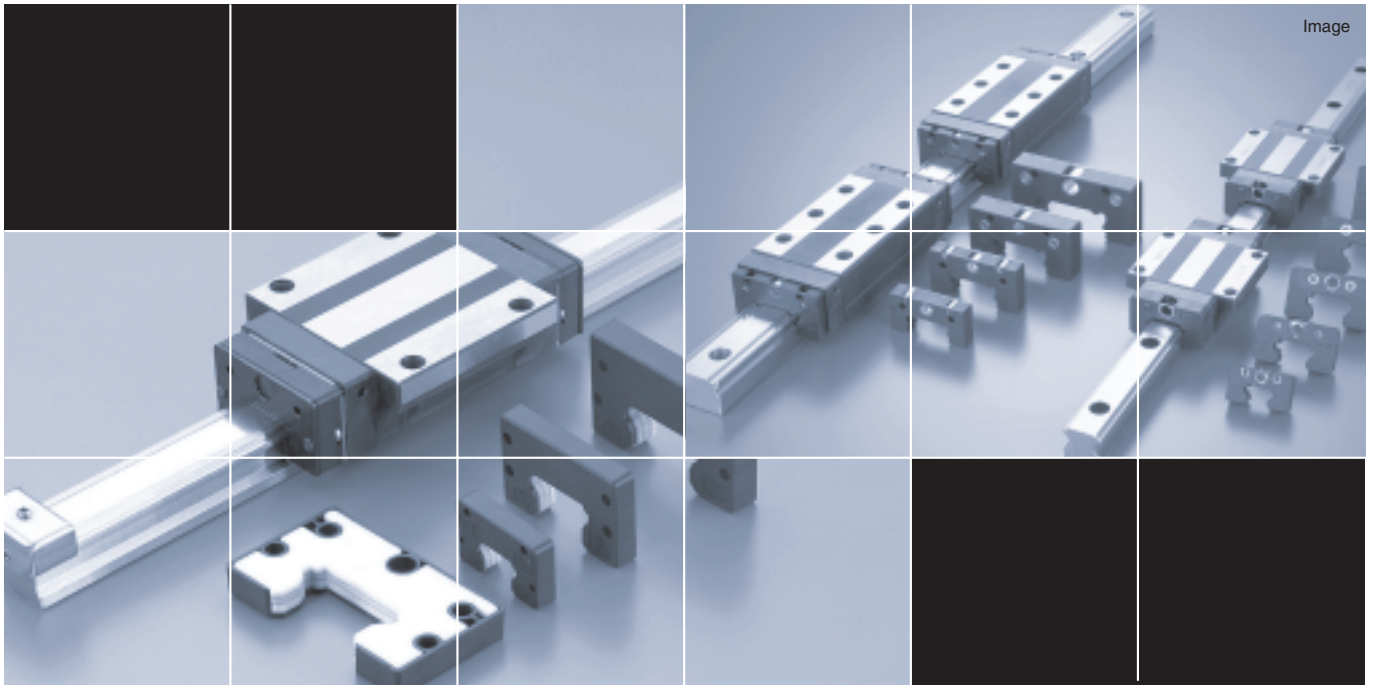

# SRS OPTIONS

## Options

For model SRS, dust-prevention and lubrication accessories are available. Make a selection according to the application and the installation site.

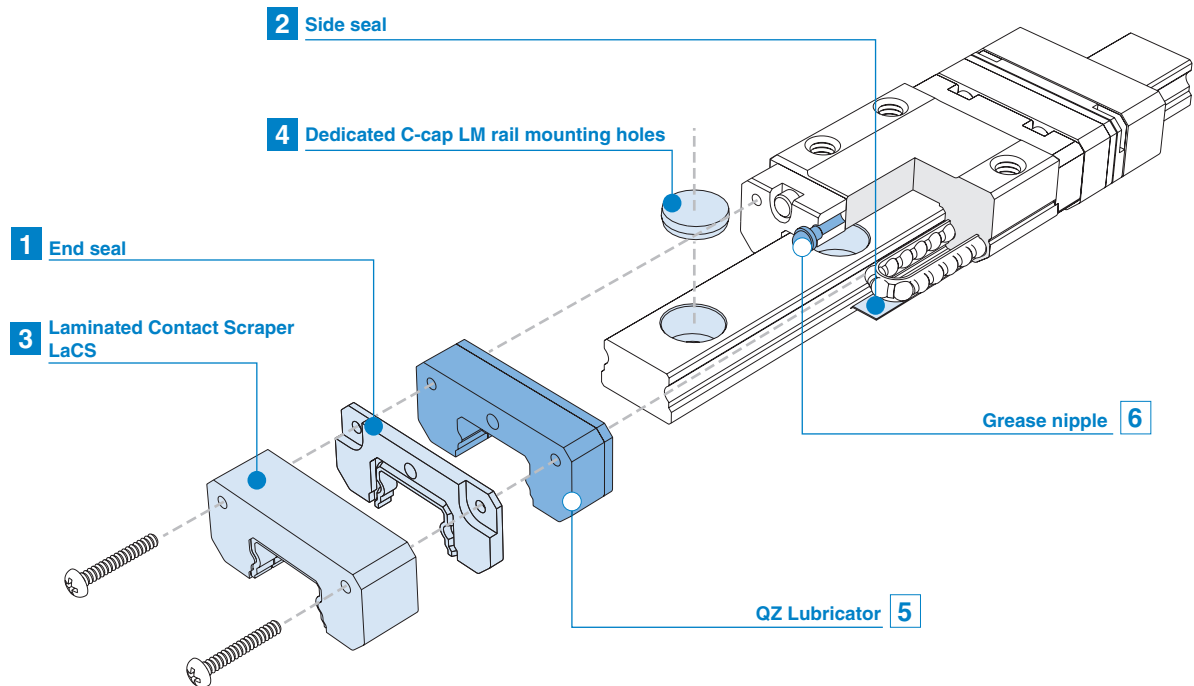

# Dust Prevention Accessories

When foreign matter enters an LM system, it will cause abnormal wear or shorten the service life. It is necessary to prevent foreign matter from entering the system. Therefore, when possible entrance of foreign matter is predicted, it is important to select an effective sealing device or dust-prevention device that meets the working conditions.

## 1 End seal

Used in locations exposed to dust.

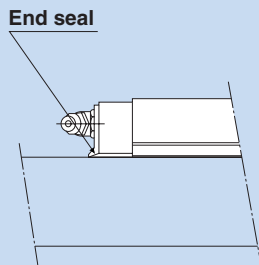

## 2 Side seal

Used in locations where dust may enter the LM block from the side or bottom surface, such as vertical, horizontal and inverted mount.

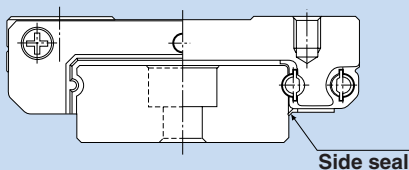

## Seals and Scraper

### 1 2 Seals

Highly wear-resistant end seals made of special resin rubber and side seals for increased dust-prevention effect are available.

If desiring a dust-prevention accessory, specify it with the corresponding symbol indicated in table 3.

For the supported model numbers for dust-prevention accessories and the overall LM block length with a dust-prevention accessory attached (dimension L), see table 4.

### Seal resistance value

For the maximum seal resistance value per LM block when a lubricant is applied on seal SRS ... SS, refer to the corresponding value provided in table 1.

Table 1 Maximum Seal Resistance Value of Seal SRS ... SS

Unit: N

Model No.	Seal resistance value	Model No.	Seal resistance value
5M*	0.06	12WM	1.30
5WM*	0.08	12WN	1.40
7M	0.08	15M	1.00
7WM	0.12	15N	1.10
9M	0.20	15WM	1.60
9N	0.30	15WN	1.60
9WM	1.00	20M	1.30
9WN	1.00	25M	1.60
12M	0.60		
12N	0.60		

\*The figure represents the maximum resistance of UU seals, models 5M and 5WM only support UU seal option.

### 3 Scraper

## Laminated Contact Scraper LaCS®

For locations with an even more adverse working conditions, the Laminated Contact Scraper LaCS is available.

LaCS removes minute foreign matter adhering to the LM rail in multiple stages and prevents it from entering the LM block with a laminated contact structure (3-layer scraper).

### Features

- Since the 3 layers of scrapers fully contact the LM rail, LaCS is highly capable of removing minute foreign matter.
- Since it uses oil-impregnated, foam synthetic rubber with a self-lubricating function, low friction resistance is achieved.

### Basic Specifications of LaCS

- ① Service temperature range of LaCS:  $-20^{\circ}\text{C}$  to  $+80^{\circ}\text{C}$
- ② Resistance of LaCS: indicated in table 2

\*Note that LaCS is not sold alone.

Table 2 Resistance of LaCS

Unit: N

Model No.	Resistance of LaCS	Model No.	Resistance of LaCS
9M	2.3	15M	5.1
9WM	3.3	15WM	7.5
12M	3.5	20M	5.2
12WM	4.2	25M	7.8

Note 1: Each resistance value in the table only consists of that of LaCS, and does not include sliding resistances of seals and other accessories.

Note 2: For the maximum service speed of LaCS, contact THK.

Table 3 Symbols of Dust Prevention Accessories for Model SRS

Symbol	Dust prevention accessory
UU	With end seal
SS	With end seal + side seal
SSHH	With end seal + side seal + LaCS

Table 4 Overall LM Block Length (Dimension L) of Model SRS with a Dust Prevention Accessory Attached

Unit: mm

Model No.	None	UU	SS	SSHH
5M	15.2	16.9	—	—
5WM	20.4	22.1	—	—
7M	21	23.4	23.4	—
7WM	28.6	31	31	—
9M	27.8	30.8	30.8	42.4
9N	37.8	40.8	40.8	52.4
9WM	36	39	39	50.6
9WN	47.7	50.7	50.7	62.3
12M	31.4	34.4	34.4	46
12N	44.1	47.1	47.1	58.7
12WM	41.5	44.5	44.5	56.1
12WN	56.5	59.5	59.5	71.1
15M	40	43	43	57.2
15N	57.8	60.8	60.8	75
15WM	52.5	55.5	55.5	69.7
15WN	71.5	74.5	74.5	88.7
20M	47	50	50	65.2
25M	73	77	77	92.6

Note: "—" indicates not available.

#### 4 Dedicated C-cap for LM Rail Mounting Holes

If any of the LM rail mounting holes of an LM Guide is filled with cutting chips or foreign matter, they may enter the LM block structure. Entrance of such foreign matter can be prevented by covering each LM rail mounting hole with the dedicated cap so that the top of the mounting holes are on the same level as the LM rail top face.

The dedicated C-cap for LM rail mounting holes is highly durable since it uses a special synthetic resin with high oil resistance and high wear resistance.

When placing an order, specify the desired cap type with the corresponding cap number indicated in the table.

Model No.	C-cap model No.	Bolt used	Major dimensions mm	
			D	H
9WM	C3	M3	6.3	1.2
12M	C3	M3	6.3	1.2
15M	C3	M3	6.3	1.2
20M	C5	M5	9.8	2.4
25M	C6	M6	11.4	2.7

#### LaCS

3

Used in harsh environments exposed to foreign matter such as fine dust and liquids.

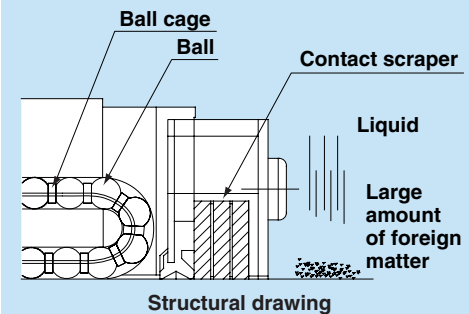

#### Dedicated C-cap

4

It prevents cutting chips from entering the LM rail mounting holes.

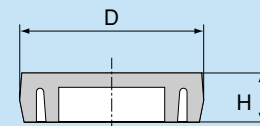

## Lubrication Accessories

### 5 QZ Lubricator

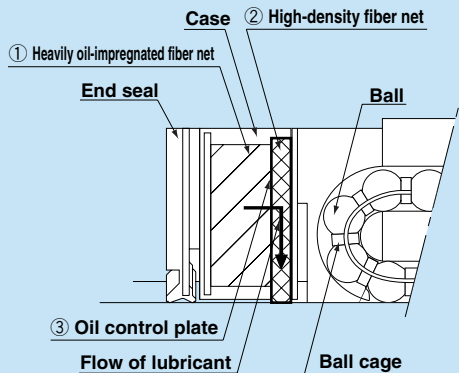

The structure of the QZ Lubricator consists of three major components:

- ① a heavily oil-impregnated fiber net (functions to store lubricant).
- ② a high-density fiber net (functions to apply lubricant to the raceway).
- ③ an oil-control plate (functions to adjust oil flow).

The lubricant contained in the QZ Lubricator is fed by the capillary phenomenon, which is used also in felt pens and many other products, as the fundamental principle.

### 5 QZ Lubricator™

The QZ Lubricator feeds the right amount of lubricant to the ball raceway on the LM rail. This allows an oil film to continuously be formed between the balls and the raceway, and drastically extends the lubrication and maintenance intervals.

When the QZ Lubricator is required, specify the desired type with the corresponding symbol indicated in table 1.

For supported LM Guide model numbers for the QZ Lubricator and overall LM block length with the QZ Lubricator attached (dimension L), see table 2.

#### Features

- Supplements lost oil to drastically extend the lubrication/maintenance interval.
- Eco-friendly lubrication system that does not contaminate the surrounding area since it feeds the right amount of lubricant to the ball raceway.
- The user can select a type of lubricant that meets the intended use.

#### Significant Extension of the Maintenance Interval

Attaching the QZ Lubricator helps extend the maintenance interval throughout the whole load range from the light-load area to the heavy-load area.

\*Note that the QZ Lubricator is not sold alone.

\*Those models equipped with the QZ Lubricator cannot have a grease nipple.

When desiring both the QZ Lubricator and a grease nipple to be attached, contact THK.

Table 1 Parts Symbols for Model SRS with the QZ Lubricator Attached

Symbol	Dust prevention accessories for the LM Guide with the QZ Lubricator attached
QZUU	With end seal + QZ Lubricator
QZSS	With end seal + side seal + QZ Lubricator
QZSSH	With end seal + side seal + LaCS + QZ Lubricator

Table 2 Overall LM Block Length (Dimension L) of Model SRS with the QZ Lubricator Attached

Model No.	Unit: mm		
	QZUU	QZSS	QZSSH
5M	—	—	—
5WM	—	—	—
7M	33.4	33.4	—
7WM	41	41	—
9M	40.8	40.8	52.4
9N	50.8	50.8	62.4
9WM	49	49	60.6
9WN	60.7	60.7	72.3
12M	44.4	44.4	56
12N	57.1	57.1	69.1
12WM	54.5	54.5	66.1
12WN	69.5	69.5	81.1
15M	55	55	69.2
15N	72.8	72.8	87
15WM	67.5	67.5	81.7
15WN	86.5	86.5	100.9
20M	66	66	81.2
25M	97	97	112.6

Note: "—" indicates not available.

**6 Grease Nipple**

Model SRS does not have a grease nipple as standard. For the location for attaching the grease nipple, see the figure on the right. Installation of a grease nipple and the drilling of a greasing hole are performed at THK. When ordering SRS, indicate that the desired model requires a grease nipple or greasing hole (for greasing hole dimensions, supported LM Guide model numbers for grease nipples and incremental dimensions, see the table below).

Table of Grease Nipple and Greasing Hole Dimensions

Unit: mm

Model No.	E	Grease nipple or greasing hole
5M	—	φ 0.8 drilled hole
5WM	—	φ 0.8 drilled hole
7M	—	φ 1.2 drilled hole
7WM	—	φ 1.2 drilled hole
9M	—	φ 1.5 drilled hole
9WM	—	φ 1.6 drilled hole
12M	—	φ 2.0 drilled hole
12WM	—	φ 2.0 drilled hole
15M	4.0 (5.0)	PB107
15WM	4.0 (5.0)	PB107
20M	3.5 (5.0)	PB107
25M	4.0 (5.5)	PB1021B

Note: Figures in the parentheses indicate dimensions without a seal.

Note 1: The grease nipple is not available for models SRS7M, SRS7WM, SRS9M, SRS9WM, SRS12M and SRS12WM. They can have a greasing hole.

Note 2: Using a greasing hole other than for greasing may cause damage.

Note 3: If the model is equipped with QZ Lubricator, a greasing hole and a grease nipple cannot be attached. If desiring to attach a grease nipple to the model equipped with QZ Lubricator, contact THK.

**■When Dust Prevention Accessories UU or SS are Attached**

For the incremental dimension of the grease nipple when dust prevention accessories UU or SS are attached, see the table above.

**■When Dust Prevention Accessories SSHH are Attached**

When dust prevention accessories SSHH are attached, the grease nipple can be mounted in the location indicated in the figure on the right. The table below shows incremental dimensions with the grease nipple.

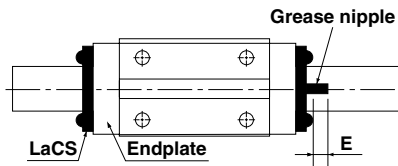

Note: When desiring the mounting location for the grease nipple other than the one indicated in the figure above, contact THK.

Unit: mm

Model No.	Incremental dimension with grease nipple E	Nipple type
25M	4	PB1021B

**Grease nipple**

**6**

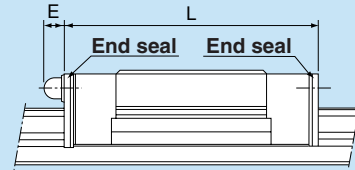

Note: For dimension L, see the corresponding dimension table.

# THK Caged Ball LM Guide Model SRS

## Precautions on use

### ● Handling

- Disassembling components may cause dust to enter the system or degrade mounting accuracy of parts. Do not disassemble the product.
- Tilting an LM block or LM rail may cause them to fall by their own weight.
- Dropping or hitting the LM Guide may damage it. Giving an impact to the LM Guide could also cause damage to its function even if the guide looks intact.

### ● Lubrication

- Thoroughly remove anti-corrosion oil and feed lubricant before using the product.
- Do not mix lubricants of different physical properties.
- In locations exposed to constant vibrations or in special environments such as clean rooms, vacuum and low/high temperature, normal lubricants may not be used. Contact THK for details.
- When planning to use a special lubricant, contact THK before using it.
- When adopting oil lubrication, the lubricant may not be distributed throughout the LM system depending on the mounting orientation of the system. Contact THK for details.
- Lubrication interval varies according to the service conditions. Contact THK for details.

### ● Precautions on Use

- Entrance of foreign matter may cause damage to the ball circulating path or functional loss. Prevent foreign matter, such as dust or cutting chips, from entering the system.
- When planning to use the LM system in an environment where coolant penetrates the LM block, it may cause trouble to product functions depending on the type of coolant. Contact THK for details.
- Do not use the LM system at temperature of 80°C or higher. When desiring to use the system at temperature of 80°C or higher, contact THK in advance.
- If foreign matter adheres to the LM system, replenish the lubricant after cleaning the product. For available types of detergent, contact THK.
- When using the LM Guide with an inverted mount, breakage of the endplate due to an accident or the like may cause balls to fall out and the LM block to come off from the LM rail and fall. In these cases, take preventive measures such as adding a safety mechanism for preventing such falls.
- When using the LM system in locations exposed to constant vibrations or in special environments such as clean rooms, vacuum and low/high temperature, contact THK in advance.
- When removing the LM block from the LM rail and then replacing the block, an LM block mounting/removing jig that facilitates such installation is available. Contact THK for details.

### ● Storage

- When storing the LM Guide, enclose it in a package designated by THK and store it in a horizontal orientation while avoiding high temperature, low temperature and high humidity.

### ● “LM GUIDE” and “” are registered trademarks of THK CO., LTD.

- The photo may differ slightly in appearance from the actual product.
  - The appearance and specifications of the product are subject to change without notice. Contact THK before placing an order.
  - Although great care has been taken in the production of this catalog, THK will not take any responsibility for damage resulting from typographical errors or omissions.
  - For the export of our products or technologies and for the sale for exports, THK in principle complies with the foreign exchange law and the Foreign Exchange and Foreign Trade Control Law as well as other relevant laws.
- For export of THK products as single items, contact THK in advance.

All rights reserved

# THK CO., LTD.

HEAD OFFICE 3-11-6, NISHI-GOTANDA, SHINAGAWA-KU, TOKYO 141-8503 JAPAN  
INTERNATIONAL SALES DEPARTMENT PHONE:+81-3-5434-0351 FAX:+81-3-5434-0353  
Global site : <http://www.thk.com/>

#### NORTH AMERICA

THK America, Inc.

##### ● HEADQUARTERS

Phone:+1-847-310-1111 Fax:+1-847-310-1271

##### ● CHICAGO OFFICE

Phone:+1-847-310-1111 Fax:+1-847-310-1182

##### ● NEW YORK OFFICE

Phone:+1-845-369-4035 Fax:+1-845-369-4909

##### ● ATLANTA OFFICE

Phone:+1-770-840-7990 Fax:+1-770-840-7897

##### ● LOS ANGELES OFFICE

Phone:+1-949-955-3145 Fax:+1-949-955-3149

##### ● SAN FRANCISCO OFFICE

Phone:+1-925-455-8948 Fax:+1-925-455-8965

##### ● BOSTON OFFICE

Phone:+1-781-575-1151 Fax:+1-781-575-9295

##### ● DETROIT OFFICE

Phone:+1-248-858-9330 Fax:+1-248-858-9455

##### ● TORONTO OFFICE

Phone:+1-905-820-7800 Fax:+1-905-820-7811

#### SOUTH AMERICA

THK Brasil LTDA

Phone:+55-11-3767-0100 Fax:+55-11-3767-0101

#### EUROPE

THK GmbH

##### ● EUROPEAN HEADQUARTERS

Phone:+49-2102-7425-0 Fax:+49-2102-7425-217

##### ● DÜSSELDORF OFFICE

Phone:+49-2102-7425-0 Fax:+49-2102-7425-299

##### ● FRANKFURT OFFICE

Phone:+49-2102-7425-650 Fax:+49-2102-7425-699

##### ● STUTTGART OFFICE

Phone:+49-7150-9199-0 Fax:+49-7150-9199-888

##### ● MÜNCHEN OFFICE

Phone:+49-8937-0616-0 Fax:+49-8937-0616-26

##### ● U.K. OFFICE

Phone:+44-1908-30-3050 Fax:+44-1908-30-3070

##### ● ITALY MILANO OFFICE

Phone:+39-039-284-2079 Fax:+39-039-284-2527

##### ● ITALY BOLOGNA OFFICE

Phone:+39-051-641-2211 Fax:+39-051-641-2230

##### ● SWEDEN OFFICE

Phone:+46-8-445-7630 Fax:+46-8-445-7639

##### ● AUSTRIA OFFICE

Phone:+43-7229-51400 Fax:+43-7229-51400-79

##### ● SPAIN OFFICE

Phone:+34-93-652-5740 Fax:+34-93-652-5746

##### ● TURKEY OFFICE

Phone:+90-216-362-4050 Fax:+90-216-569-7150

##### ● PRAGUE OFFICE

Phone:+420-2-41025-100 Fax:+420-2-41025-199

THK France S.A.S.

Phone:+33-4-3749-1400 Fax:+33-4-3749-1401

#### CHINA

THK (CHINA) CO.,LTD.

##### ● HEADQUARTERS

Phone:+86-411-8733-7111 Fax:+86-411-8733-7000

##### ● SHANGHAI OFFICE

Phone:+86-21-6219-3000 Fax:+86-21-6219-9890

##### ● BEIJING OFFICE

Phone:+86-10-8441-7277 Fax:+86-10-6590-3557

##### ● CHENGDU OFFICE

Phone:+86-28-8526-8025 Fax:+86-28-8525-6357

##### ● GUANGZHOU OFFICE

Phone:+86-20-8523-8418 Fax:+86-20-3801-0456

THK (SHANGHAI) CO.,LTD.

Phone:+86-21-6275-5280 Fax:+86-21-6219-9890

#### TAIWAN

THK TAIWAN CO.,LTD.

##### ● TAIPEI HEAD OFFICE

Phone:+886-2-2888-3818 Fax:+886-2-2888-3819

##### ● TAICHUNG OFFICE

Phone:+886-4-2359-1505 Fax:+886-4-2359-1506

##### ● TAINAN OFFICE

Phone:+886-6-289-7668 Fax:+886-6-289-7669

#### KOREA

SEOUL REPRESENTATIVE OFFICE

Phone:+82-2-3468-4351 Fax:+82-2-3468-4353

#### SINGAPORE

THK LM SYSTEM Pte. Ltd.

Phone:+65-6884-5500 Fax:+65-6884-5550

#### INDIA

BANGALORE REPRESENTATIVE OFFICE

Phone:+91-80-2330-1524 Fax:+91-80-2314-8226