

Cross LM Guide CSR

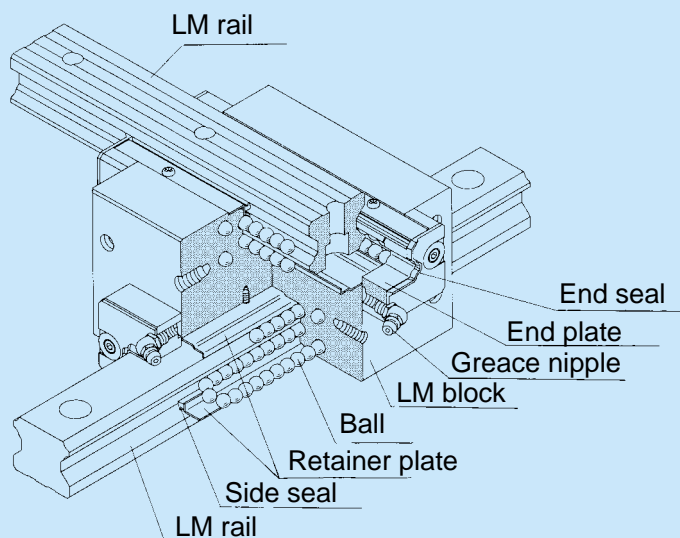

Fig. 1 Construction of Model CSR

Construction and Features

Balls roll in four rows of precision-ground raceway on an LM rail and an LM block. The end plate attached to the LM block causes the trains of balls to circulate. As the balls are held in place by the retainer plate, they do not fall off if the LM block is removed from the rail.

A CSR unit consists of two LM rails, with one rail inverted on the other and with the rails intersecting one another at right angles via a one-piece LM block of the same construction as type HSR, which has a proven record of high performance. The perpendicularity of the hexahedron of each block is of very high precision, to 2 μm per 100 mm. The right angles between the LM rails are equally precise. These jointly ensure very high precision of the perpendicularity of the cross structure. CSR alone can constitute a cross linear motion system and can therefore eliminate the need for a conventional saddle. The result is a simplified X-Y-motion design and a system compact in size.

Four-way equal load

The raceways are arranged at 45° in relation to one another, so that each train of balls bears an equal load rating in all four directions: radial, reverse-radial, and the two lateral directions. This type, which can be used in any installation direction, can therefore be put to a wide range of uses.

High rigidity

The rows of balls provide the host LM Guide system with good balance and therefore high resistance to moments. Even under a preload applied to improve rigidity, the system provides smooth linear motion.

The rigidity of the one-piece LM block of this type is at least 50% greater than that of two blocks of type HSR bolted to one another, with one of them inverted on the other. Thus, type CSR is best suited for X-Y tables that require high rigidity.

Load Rating and Permissible Moment in Various Directions

Load rating

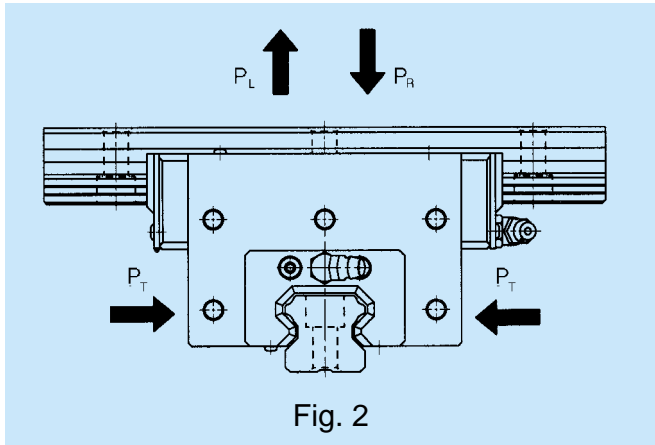

Type CSR can bear loads applied in all four directions: radial, reverse-radial, and the two lateral directions.

The basic load rating is defined for one LM rail and one LM block and is equal in all four directions (radial, reverse-radial, and the two lateral directions). Values are given in the corresponding dimension tables.

Equivalent load

The equivalent load for type CSR when loads applied in all four directions are applied to its LM block simultaneously can be obtained using the following equation:

$$P_E = P_R (P_L + P_T)$$

where

- P_E : equivalent load (N)
- In the radial direction
- In the reverse-radial direction
- In the lateral direction

P_R : radial load (N)

P_L : reverse-radial load (N)

P_T : lateral load (N)

Permissible moment

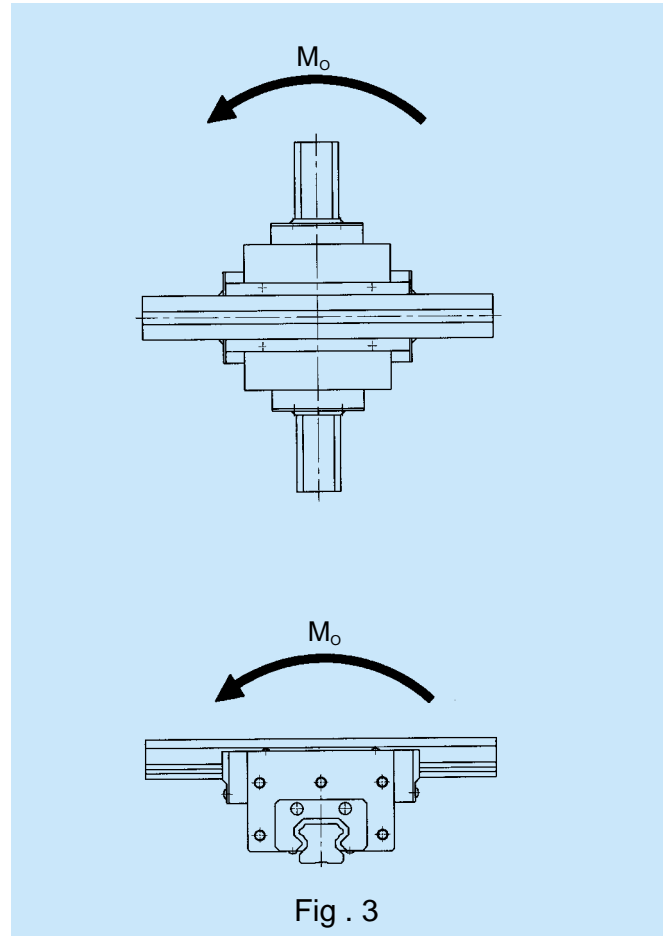

In type CSR, a single LM block can bear all moments in the four directions. The magnitudes of the moments are equal in the four directions. Table 1 gives the values for permissible moments on a single LM block.

Table 1 Type CSR Static Permissible Moment

Unit : kNm

Model No.	M_0
CSR 15	0.07
CSR 20S	0.16
CSR 20	0.27
CSR 25S	0.27
CSR 25	0.46
CSR 30S	0.43
CSR 30	0.73
CSR 35	1.1
CSR 45	2.1

Accuracy Standards

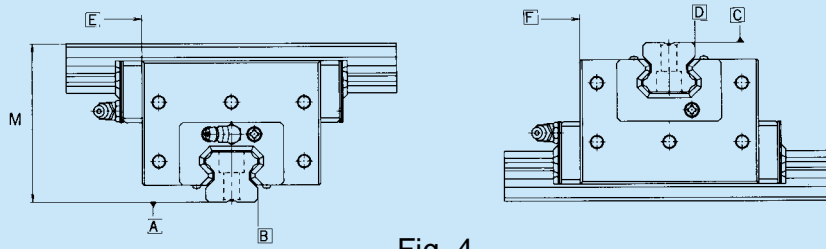

Fig. 4

The accuracy of type CSR is given in Table 2 for each model number.

Table 2 Type CSR Accuracy Standard

Unit : mm

Model No.	Accuracy standard	Precision	Super-precision	Ultra-precision
	Item	P	SP	UP
CSR 15 CSR 20	Tolerance for height M	0.01	0.007	0.005
	Perpendicularity of surface D with surface B	0.005	0.004	0.003
	Running parallelism of surface E with surface B	C (as per Fig. 5)		
	Running parallelism of surface F with surface B	D (as per Fig. 5)		
CSR 25	Tolerance for height M	0.01	0.007	0.005
	Perpendicularity of surface D with surface B	0.008	0.006	0.004
	Running parallelism of surface E with surface B	C (as per Fig. 5)		
	Running parallelism of surface F with surface B	D (as per Fig. 5)		
CSR 30 CSR 35	Tolerance for height M	0.01	0.007	0.005
	Perpendicularity of surface D with surface B	0.01	0.007	0.005
	Running parallelism of surface E with surface B	C (as per Fig. 5)		
	Running parallelism of surface F with surface B	D (as per Fig. 5)		
CSR 45	Tolerance for height M	0.012	0.008	0.006
	Perpendicularity of surface D with surface B	0.012	0.008	0.006
	Running parallelism of surface E with surface B	C (as per Fig. 5)		
	Running parallelism of surface F with surface B	D (as per Fig. 5)		

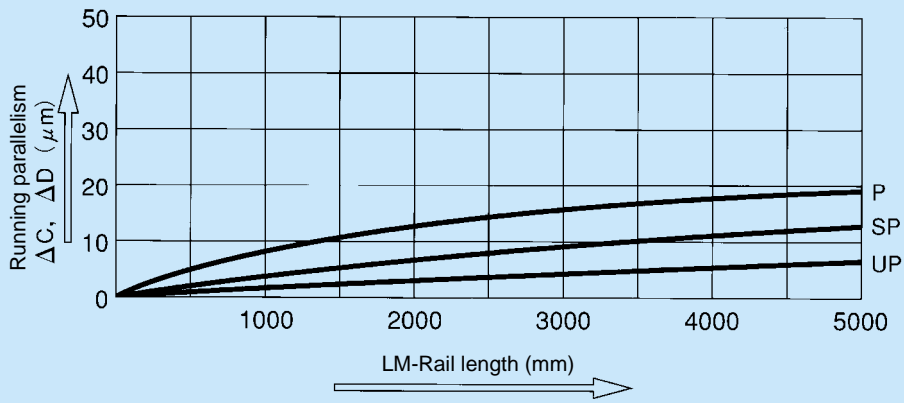

Fig. 5 Relationship Between LM-Rail Length and Running Parallelism

Radial clearance

The radial clearance of type CSR is the clearance between an LM rail and an LM block. Table 3 gives the radial clearances of type CSR.

Table 3 Type-CSR Radial Clearances

Unit: μm

Clearance symbol Model No.	Normal	Under a light preload	Medium preload
	No symbol	C1	C0
CSR 15	-4 ~ +2	-12 ~ -4	—
CSR 20S CSR 20	-5 ~ +2	-14 ~ -5	-23 ~ -14
CSR 25S CSR 25	-6 ~ +3	-16 ~ -6	-26 ~ -16
CSR 30S CSR 30	-7 ~ +4	-19 ~ -7	-31 ~ -19
CSR 35	-8 ~ +4	-22 ~ -8	-35 ~ -22
CSR 45	-10 ~ +5	-25 ~ -10	-40 ~ -25

Model-number coding

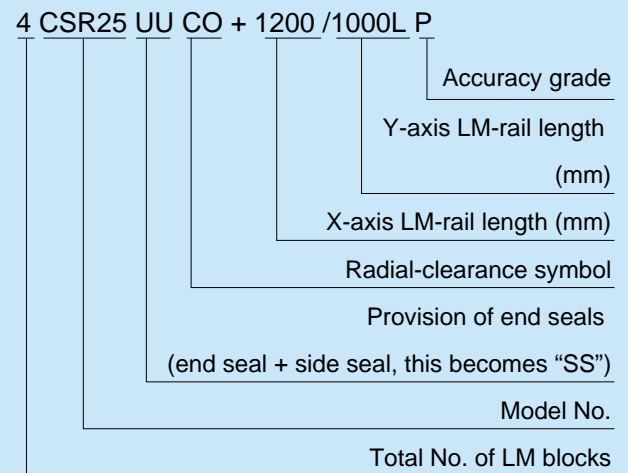

Note: To place an order, please contact us.

Contamination Protection

From our wide array of products for type CSR, you can select the one best suited for your situation. (For details on seals, see “Contamination Protection” for type HSR on page A-249.)

If your choice is applicable to your system, please note that in some models, attaching a contamination-protection accessory to an LM block changes the block’s overall length. Add the increment specified in the corresponding dimension table to dimension L.

Not all LM Guide models accept all contamination-protection accessories. Please check Table 4.

Table 4 Type CSR: LM Block Overall Length with a Contamination-protection Accessory Attached

Unit : mm

Model No.	No symbol		UU		SS		DD		ZZ		KK		LL		RR	
CSR 15	○	51.5	○	56.5	○	56.5	○	61.7	△	58.1	△	63.3	○	56.5	○	56.5
CSR 20S CSR 20	○	68 84	○	74 90	○	74 90	○	80.6 96.6	○	76.6 92.6	○	83.2 99.2	○	74 90	○	74 90
CSR 25S CSR 25	○	76 95.5	○	83 102.5	○	83 102.5	○	90.6 110.1	○	85.6 105.1	○	93.2 112.7	○	83 102.5	○	83 102.5
CSR 30S CSR 30	○	91 113.5	○	98 120.5	○	98 120.5	○	105.6 128.1	○	100.6 123.1	○	108.2 130.7	○	98 120.5	○	98 120.5
CSR 35	○	128	○	135	○	135	○	142.6	○	137.6	○	145.2	○	135	○	135
CSR 45	○	164	○	171	○	171	○	178.2	○	176.2	○	183.4	○	171	○	171

Note: ○ = Applicable

△ = Applicable, but a grease nipple cannot be attached; contact us

Seal resistance

With regard to end seals for type CSR...UU, Table 5 gives the maximum values for seal resistance to one LM rail per LM block with a lubricant applied.

Table 5 Maximum Resistance Value of seals to Type CSR

Unit : N

Model No.	Seal resistance value
CSR 15	2.0
CSR 20	2.5
CSR 25	3.9
CSR 30	7.8
CSR 35	11.8
CSR 45	19.6

LM-Rail Standard and Maximum Lengths

For the LM-rail standard and maximum lengths for type CSR, see “LM-Rail Standard and Maximum Lengths” for type HSR on page A-256.

Precautions on Use

Mounting-Surface Height and Corner Profile

Normally, mounting surfaces for LM blocks and rails have lateral reference surfaces to aid in positioning rails and blocks with a high degree of accuracy.

For the reference-surface shoulder height, see Table 6.

Furthermore, provide enough space to the corner profile of a mounting surface so that the corner does not interfere with chamfers made on the LM blocks or rails, or provide the corner with a radius smaller than corner radius r specified in Table 6.

Table 6 Mounting-Surface Shoulder Height and Corner Radius

Unit: mm

Model No.	Corner radius r (Max.)	LM-rail shoulder height H_1	E
CSR 15	0.5	3	3.5
CSR 20	0.5	3.5	4
CSR 25	1.0	5	5.5
CSR 30	1.0	5	7
CSR 35	1.0	6	7.5
CSR 45	1.0	8	10

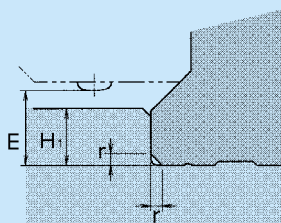
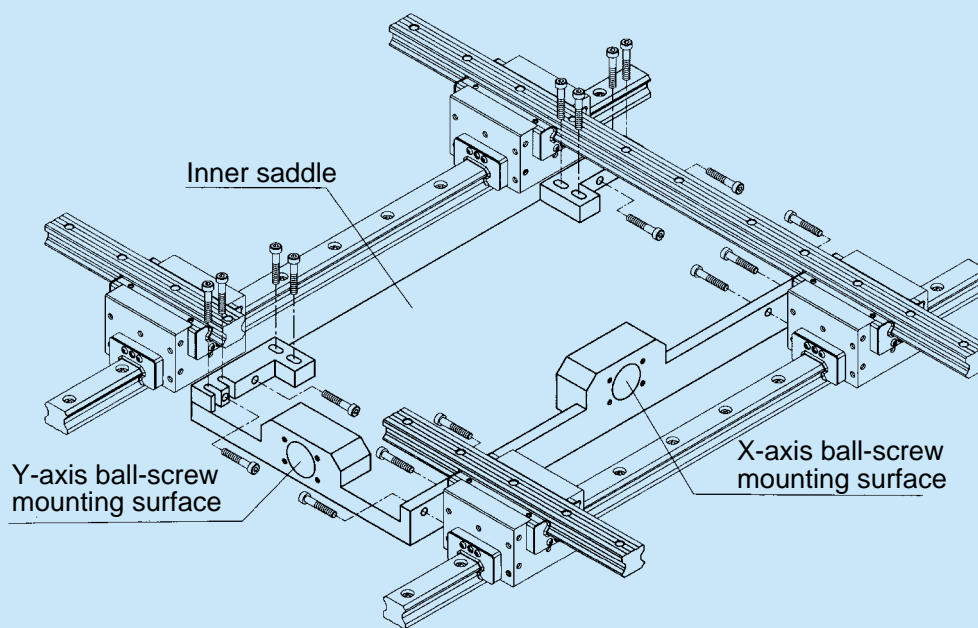

Fig. 6

Sample Application

In this sample, an inner saddle mechanism (a square board) is attached to the inner sides of four LM blocks, thereby linking them together. This makes it easy to

assemble and position the rails and blocks, enabling the creation of a high-precision X-Y guide with high rigidity against the yawing moment.



Inner saddle (with adjustment mechanism)

Cross LM Guide Type CSR



Model No.	External dimensions			LM-block dimensions												
	Height M	Width W	Length L	H	B	B ₁	n-S × l	J	A	T	C	G	K	N	E	
CSR 15	47	38.8	56.5	20	-	9.4	2-M4 × 0.7 × 6	34.8	-	-	11.3	32	3.5	19.5	5.5	
CSR 20 S	57	50.8	74	30	-	10.4	2-M5 × 0.8 × 8	42.5	-	-	13.3	42	4.0	25	12	
CSR 20		66.8	90	56	28	5.4	5-M5 × 0.8 × 8	37	13	24	7.8					
CSR 25 S	70	59.5	83	34	-	12.75	2-M6 × 10	52	-	-	17	46	5.5	30	12	
CSR 25		78.6	102.5	64	32	7.3	5-M6 × 10	44	18	26	9					
CSR 30 S	82	70.4	98	40	-	15.2	2-M6 × 10	61	-	-	20	58	7.0	35	12	
CSR 30		93	120.5	76	38	8.5	5-M6 × 10	53	21	32	12					
CSR 35	95	105.8	135	90	45	7.9	5-M8 × 14	61	24	37	14	68	7.5	40	12	
CSR 45	118	129.8	171	110	55	9.9	5-M10 × 15	75	30	45	16	84	10.0	50	16	

Note:

- For permissible static moments M_0 , see page A-289.

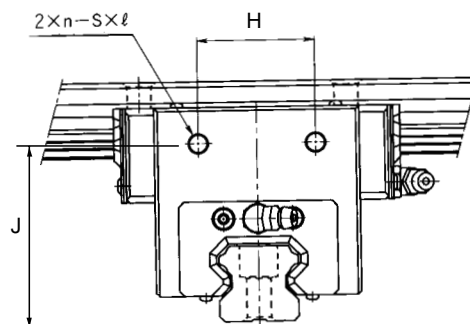

CSR15, 20S, 25S, 30S

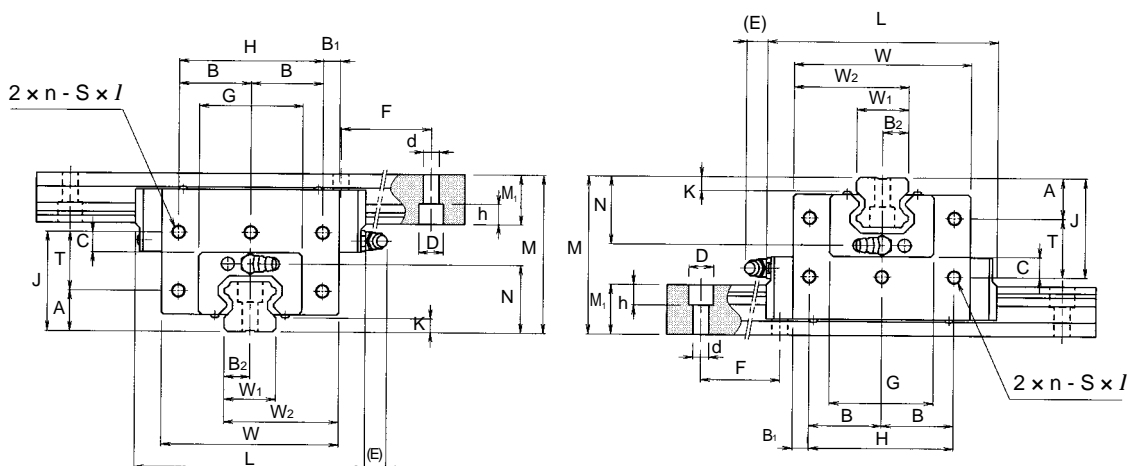

Unit : mm

Grease nipple	LM-rail dimensions						Basic load rating		Mass	
	Width W_1 ± 0.05	W_2	B_2	Height M_1	Pitch F	$d \times D \times h$	C kN	C_0 kN	LM block kg	LM rail kg/m
PB1021B	15	26.9	7.5	15	60	4.5x7.5x 5.3	8.33	13.5	0.34	1.5
B-M6F	20	35.4 43.4	10	18	60	6 x 9.5 x 8.5	13.8 21.3	23.8 31.8	0.73 1.3	2.3
B-M6F	23	41.25 50.8	11.5	22	60	7 x 11 x 9	19.9 27.2	34.4 45.9	1.2 2.2	3.3
B-M6F	28	49.2 60.5	14	26	80	9 x 14 x 12	28.0 37.3	46.8 62.5	2.0 3.6	4.8
B-M6F	34	69.9	17	29	80	9 x 14 x 12	50.2	81.5	5.3	6.6
B-PT1/8	45	87.4	22.5	38	105	14 x 20 x 17	80.4	127.5	9.8	11.0

Notes:

- For the LM-rail standard length, see “LM-Rail Standard and Maximum Lengths” on page A-256.
- For model-number coding, see page A-291.