

# **SNR/SNS** *Caged Ball LM Guide*

*Ultra-rigid LM Guide®  
for Machine Tools*



- High speed performance
- Low noise design
- Reduction in rolling resistance variation
- Fitting measurements according to DIN 645
- Long-term maintenance-free operation
- Radius of curvature 51% Da

**THK CO., LTD.**  
TOKYO, JAPAN

Catalog No. 234-7E

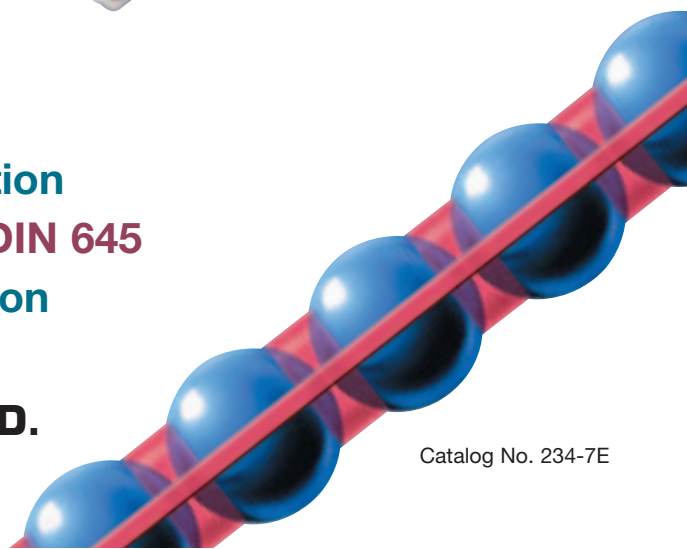

# SNR/SNS

## Ultra-rigid LM Guide with Caged Ball™ Technology

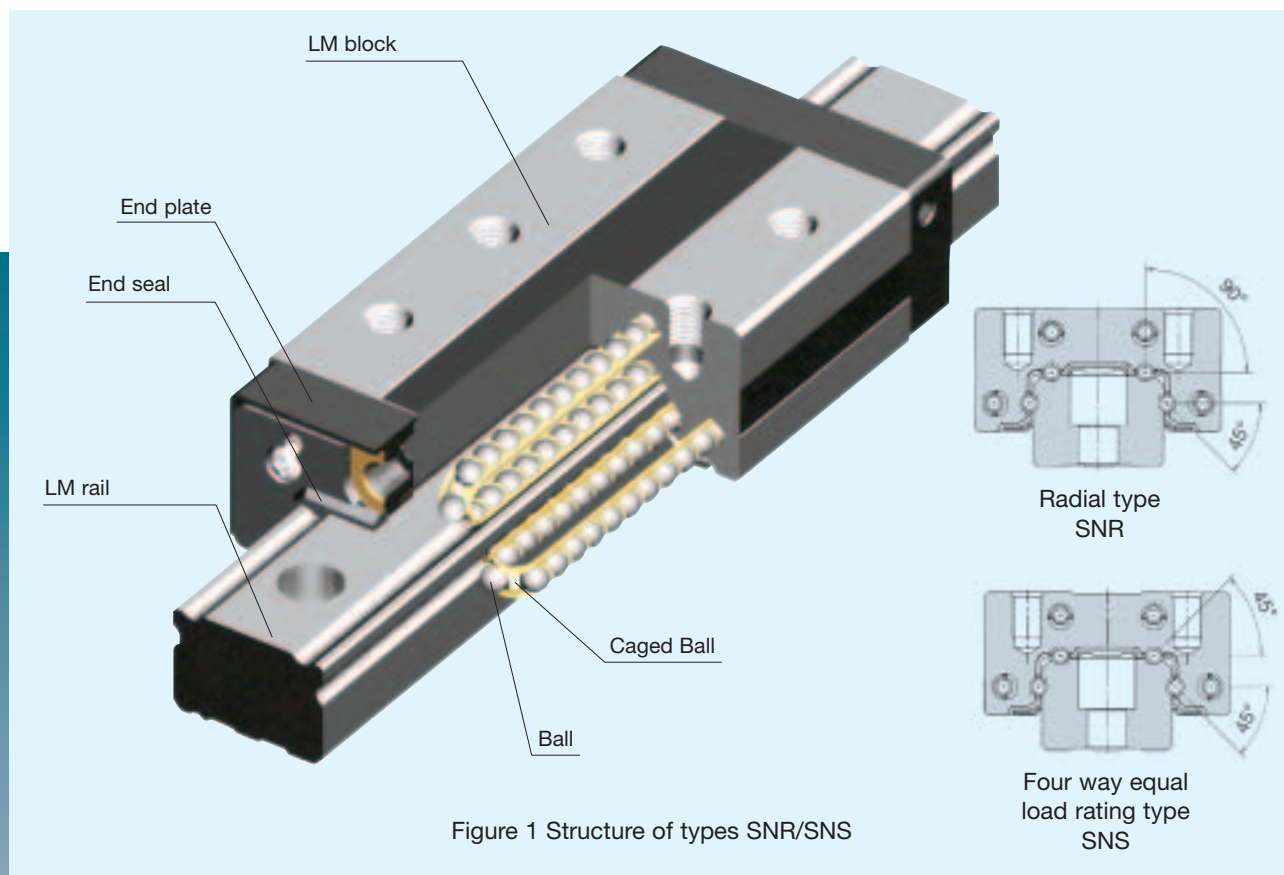

### Fitting measurements also according to DIN 645

The fitting measurements of the types SNR-H and SNS-H meet the standard DIN 645. Therefore, these types are compatible with all standard roller as well as ball type linear motion guides. For very compact machine designs the extremely compact linear guides SNR and SNS are the best solutions.

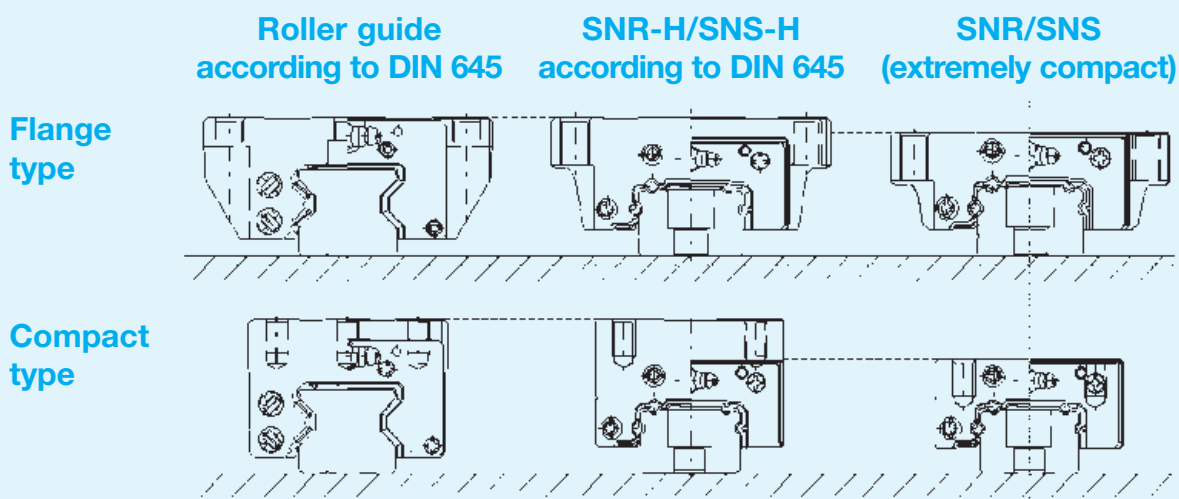

# SNR/SNS

## CAGED BALL LM GUIDE

### Elimination of Ball-Friction with Caged Ball™ technology

#### Linear motion guide

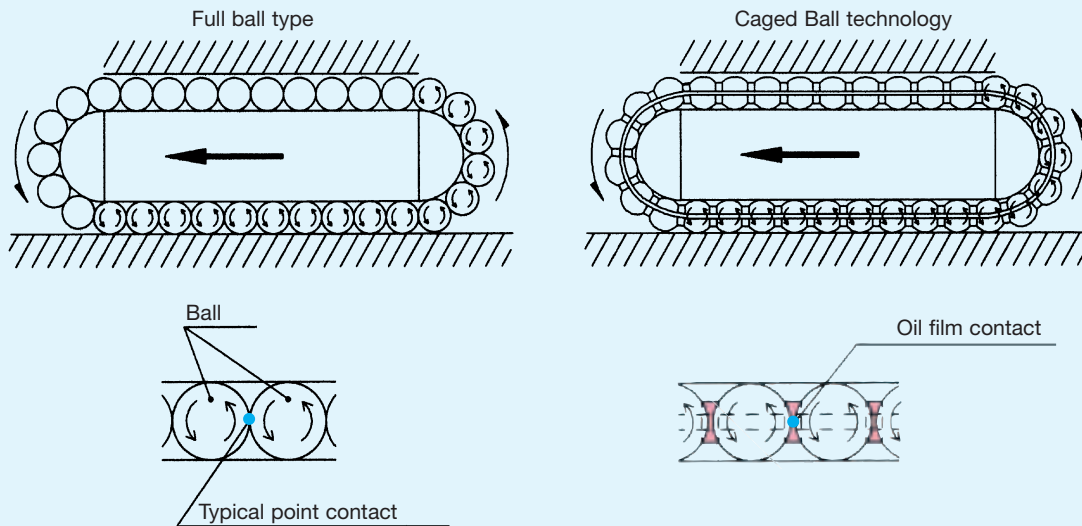

#### Rotary ball bearing

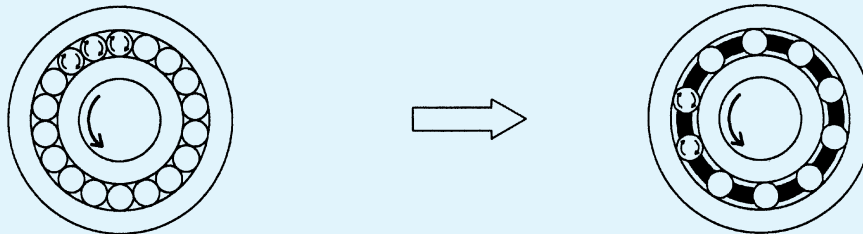

##### In the first stage of development (Full ball type)

- Adjacent balls contact each other at a point. As a result, the contact stress is large and the oil film breaks down due to friction.
- The life becomes shorter.

At the time rotary ball bearings were invented, they had no ball cages. This resulted in loud noise during operation, a short running life, and did not have the ability to be run at high speeds.

20 years later, rotary ball bearings with ball cages were developed. This type was quieter in operation and capable of high rotational speeds. Although containing less balls, it provided excellent running life and contributed to the major success of rotary bearings.

The history of the needle bearing reveals how quality improved through the use of ball cages. Balls, at their

##### Present bearing (With ball cage)

- The life is extended due to the absence of friction.
- Heat generation during high-speed rotation is limited due to the absence of the friction between adjacent balls.
- The balls do not contact each other. Noise does not arise from the metal to metal contact.
- Balls move smoothly because they are positioned evenly.
- The lubricating oil retained between the balls provides excellent lubrication and long life.

point of contact, slip against each other in opposite directions and at twice the speed of each of their rotation. This resulted in severe wear, loud noise, and a short running life. The massive pressure from the metal to metal contact and slip between the balls also caused the oil film to break down.

Alternatively, balls and ball cage contact each other over a large surface area and at half the relative velocity. This prevents the break down of oil and provides for quieter operation, higher rotational speeds, longer running life and extended maintenance.

At THK, we utilized our many years of experience along with innovative manufacturing techniques to develop the new Caged Ball™ technology, and we have built this technology into the new generation of smooth-running LM guides. The main features of the new LM guides are as follows.

### Low Noise - Favorable Sound Quality

Since the balls move in an orderly manner due to the presence of the ball cages, the metallic sound produced by collision between adjacent balls is eliminated, thereby resulting in low noise levels and favorable sound quality.

### Long Service Life, Long-term Maintenance-free Operation

Adjacent balls, separated by the ball cage, do not rub against each other and produce friction. As a result, the balls are not subject to wear and tear. In addition, the grease retention has been enhanced, providing long service life, long-term maintenance-free operation.

### Excellent High-speed performance

Caged Ball LM Guides exhibit excellent high-speed performance through reduced heat generation due to lower bearing stress and half the ball contact velocity. The life of the balls is also prolonged due to the elimination of the friction and wear between adjacent balls.

### Super Smooth Movement

Smooth movement with less variation of torque can be obtained as the balls are lined uniformly and circulated.

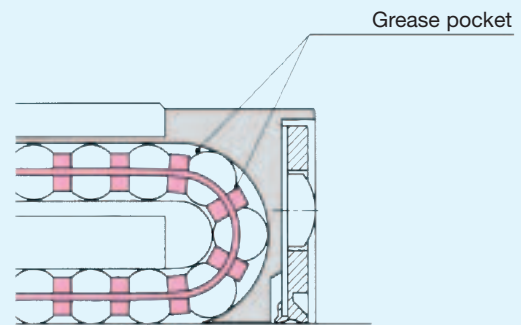
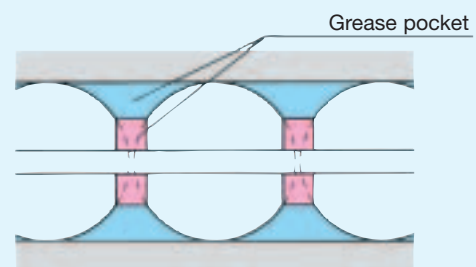

Figure 2 Ball circulating section



The grease circulates with the aid of a ball cage.

Figure 3 Grease pocket

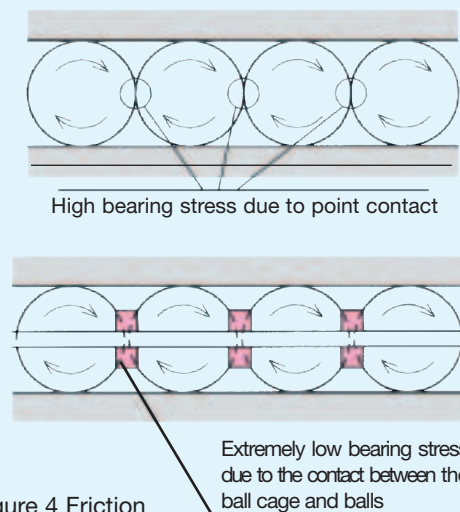

Figure 4 Friction

# SNR/SNS

## CAGED BALL LM GUIDE

### ■ Noise level data

The types SNR/SNS have ball-circulating sections made of resin molded in the block. This structure eliminates metallic noise caused by balls contacting the block. The use of a ball cage has also eliminated metallic noise produced by balls hitting each other. Thus, types SNR/SNS operate quietly even at high speed. In addition, a ball cage is effective in preventing balls from rubbing against each other, resulting in low heat generation and a super high speed performance.

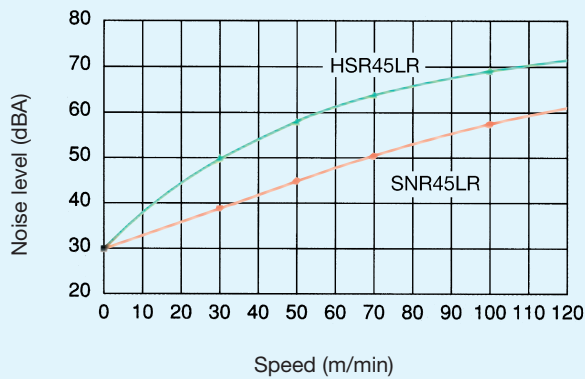

Comparison of the noise levels of SNR45LR and HSR45LR

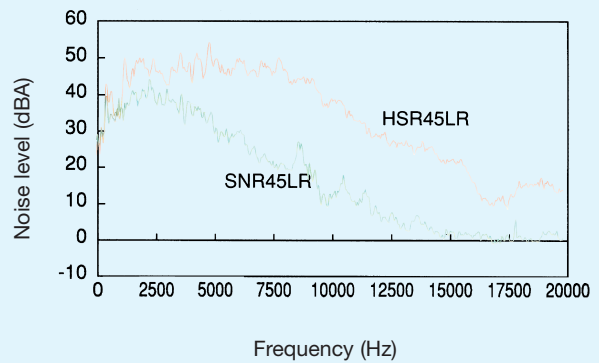

Comparison of the noise levels of SNR45LR and HSR45LR (Speed: 100 m/min)

### ■ Less variation of rolling resistance

Types SNR/SNS are equipped with ball cage that uniformly arranges the balls. This enables the balls to move in a straight line without meandering when they enter the block. The balls can move smoothly regardless of the mounting position, decreasing the variation of rolling resistance and enabling a high degree of accuracy.

#### Variation in Rolling Resistance HSR45LR (full ball type)

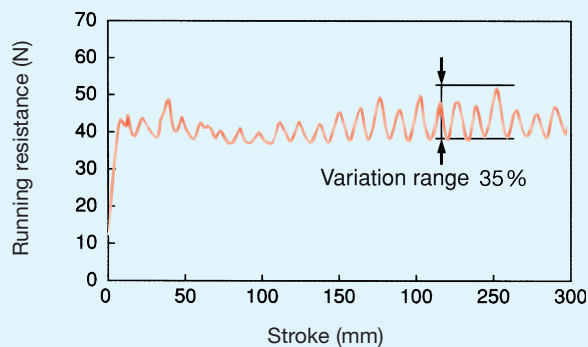

(Feeding speed: 10 mm/s)

#### Variation in Rolling Resistance SNR45LR (Caged Ball type)

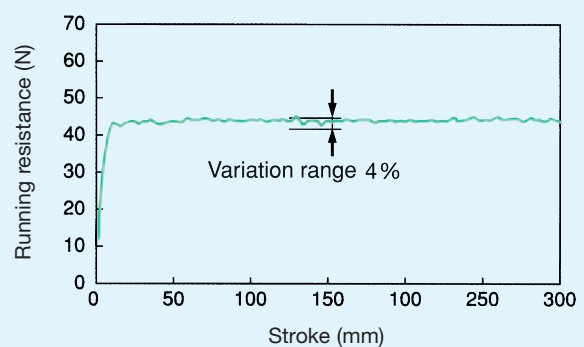

(Feeding speed: 10 mm/s)

# SNR/SNS

## CAGED BALL LM GUIDE

### Special Quality of Type SNR and SNS

#### High rigidity

Types SNR/SNS are compact linear motion products based on the design of the LM Guide type NR, but with increased block rigidity. Since the radial rigidity, reverse radial rigidity, and lateral rigidity were all increased, types SNR/SNS have the highest rigidity in the Caged Ball series. The two types are available in the same dimensions: type SNR for the radial load type and type SNS for the four way equal load rating type. Either may be selected according to your application.

#### Radial rigidity

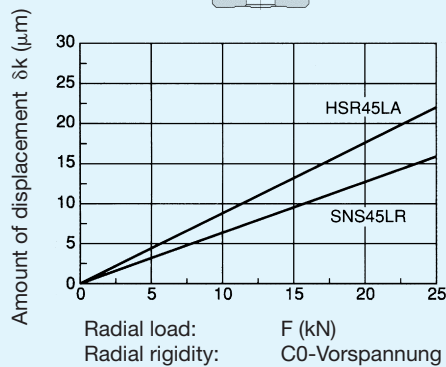
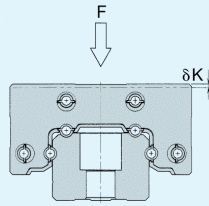

#### Reverse radial rigidity

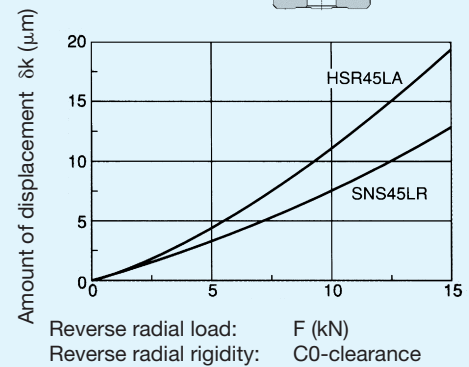
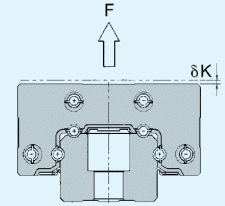

#### Improvement of damping effect

During rapid traverse movement, the LM Guide moves smoothly with almost no differential slip, and achieves high positioning accuracy. During heavy cutting and slow movement, the proper differential slip according to cutting load is generated. As a result, it increases frictional resistance and improves the damping effect (damping characteristics).

#### Ultra-heavy load specifications

The radius of curvature of the raceway is very similar to the ball radius so that the contact area, when subject to a load, is no less than the contact area of a roller type. This allows the new LM Guide to have a higher load carrying capacity than the roller type. They do not suffer a locking phenomenon due to the skewing of the rollers, which often occurs to the roller type.

#### Wide variety of options

Since various options such as the end seal, cover plate and bellows are available, the LM Guide can accommodate a variety of specifications.

# SNR/SNS

CAGED BALL LM GUIDE

## Types and Features

### SNR-RH/SNS-RH SNR-R/SNS-R

Compact type

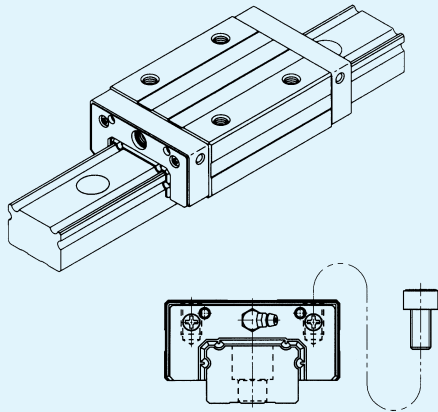

Type SNR-R has a narrow block. Threads are tapped in the block. It is used when the installation space is limited. The fitting measurements are based on DIN 645.

### SNR-CH/SNS-CH SNR-C/SNS-C

Flange type

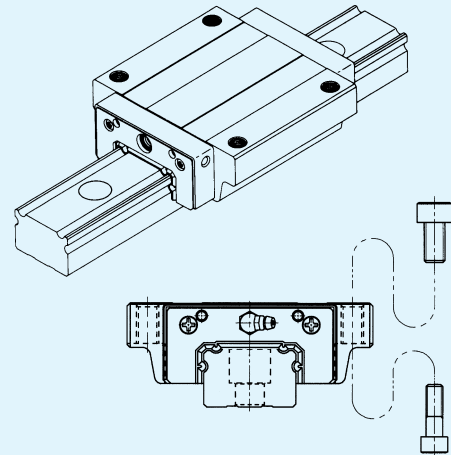

The block of type SNR-C has flanges which are tapped from the top and counterbored from below. The fitting measurements are based on DIN 645.

### SNR-LRH/SNS-LRH SNR-LR/SNS-LR

Compact type

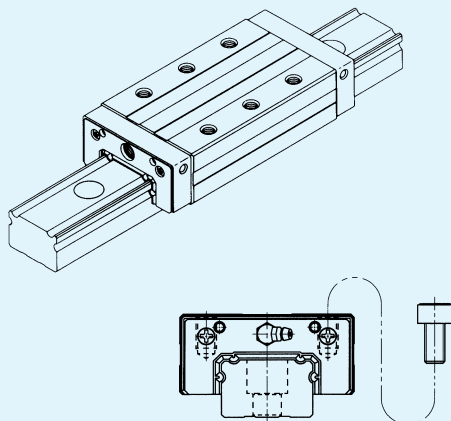

LM block threaded holes:  
SNR-LR/SNS-LR 6 pcs.  
SNR-LRH/SNS-LRH 4 pcs.

Type SNR-LR has the same cross section as type SNR-R. With the increased number of balls, it is for handling ultra-heavy loads. The fitting measurements are based on DIN 645.

### SNR-LCH/SNS-LCH SNR-LC/SNS-LC

Flange type

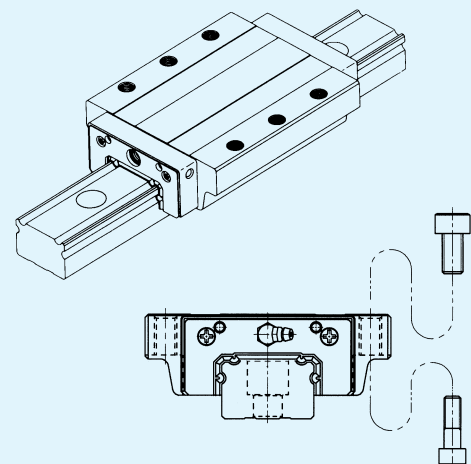

LM block threaded holes:  
SNR-LC/SNS-LC 6 pcs.  
SNR-LCH/SNS-LCH 4 pcs.

Type SNR-LC has the same cross section as type SNR-C. With the increased number of balls, it is for handling ultra-heavy loads. The fitting measurements are based on DIN 645.

## Load Ratings and Life

Types SNR/SNS can support loads in the radial, reverse radial and lateral directions.

The basic load ratings listed in the dimension tables show the load ratings in the radial direction.

### Life calculation

The following equation gives the life of types SNR/SNS.<sup>1)</sup>

$$L = \left( \frac{f_T \cdot f_C}{f_W} \cdot \frac{C}{P_C} \right)^3 \cdot 50$$

$L$  : Rated life (km)

Die nominelle Lebensdauer  $L$  ist statistisch als die Gesamtlaufstrecke definiert, die 90% einer größeren Menge gleicher Führungen unter gleichen Betriebsbedingungen erreichen oder überschreiten, bevor erste Anzeichen einer Werkstoffermüdung auftreten.

$C$  : Basic dynamic load rating (N)

$P_C$  : Design load (N)

$f_T$  : Temperature factor

$f_C$  : Contact factor

$f_W$  : Load factor

Given rated life( $L$ ) calculated by the above equation and assuming that the length of stroke and the reciprocating rate are constant, the life in terms of time can be calculated by using the following equation.

$$L_h = \frac{L \cdot 10^3}{2 \cdot \ell_S \cdot n_1 \cdot 60}$$

$L_h$  : Life in terms of time (hr) (h)

$\ell_S$  : Stroke length (m)

$n_1$  : Number of reciprocating motions per minute ( $\text{min}^{-1}$ )

## Load Ratings in Various Directions

### Load ratings

Types SNR/SNS can support loads in the radial, reverse radial and lateral directions. The basic load ratings listed in the dimension tables show the load ratings in the radial direction. The reverse radial and lateral load ratings are obtained from the table.

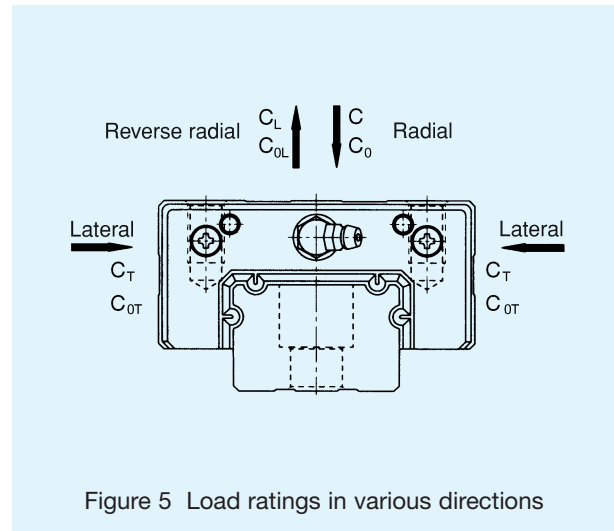

Figure 5 Load ratings in various directions

Table 1 Load ratings of types SNR/SNS in various directions

Direction	SNR		SNS	
	Basic dynamic load rating	Basic static load rating	Basic dynamic load rating	Basic static load rating
Radial	$C$	$C_0$	$C$	$C_0$
Reverse radial	$C_L=0,64C$	$C_{0L}=0,64C_0$	$C_L=0,84C$	$C_{0L}=0,84C_0$
Lateral	$C_T=0,47C$	$C_{0T}=0,38C_0$	$C_T=0,84C$	$C_{0T}=0,84C_0$

### Equivalent load

When the LM block of type SNR is subjected to reverse radial and lateral loads simultaneously, the equivalent load can be calculated by using the following equation.

$$P_E = X \cdot P_L + Y \cdot P_T$$

$P_E$  : Equivalent load

·Reverse radial

·Lateral

(N)

$P_L$  : Reverse radial load

(N)

$P_T$  : Lateral load

(N)

$X, Y$  : Equivalent factors

(Table 2)

Table 2 Equivalent factors of type SNR

	$P_E$	X	Y
$P_L/P_T \geq 1$	Reverse radial equivalent load	1	1,678
$P_L/P_T < 1$	Lateral equivalent load	0,596	1

When the LM block of type SNS is subjected to radial and lateral loads, reverse radial and lateral loads simultaneously, the equivalent load can be calculated by using the following equation.

$$P_E = X \cdot P_R (P_L) + Y \cdot P_T$$

$P_E$  : Equivalent load (N)  
 · Radial  
 · Reverse radial  
 · Lateral

$P_R$  : Radial load (N)

$P_L$  : Reverse radial load (N)

$P_T$  : Lateral load (N)

X, Y : Equivalent factors (Table 3,4)

Table 3 Equivalent factors of type SNS (in case of radial load and lateral load are applied)

	$P_E$	X	Y
$P_R/P_T \geq 1$	Radial equivalent load	1	0,935
$P_R/P_T < 1$	Lateral equivalent load	1,070	1

Table 4 Equivalent factors of type SNS (in case of reverse radial load and lateral load are applied)

	$P_E$	X	Y
$P_L/P_T \geq 1$	Reverse radial equivalent load	1	1,020
$P_L/P_T < 1$	Lateral equivalent load	0,986	1

### Radial Equivalent Load $M_0$

Types SNR/SNS can take moment load in all three directions with only one LM block. Tables 5 and 6 list the values for the permissible moment load with one LM block in three directions.

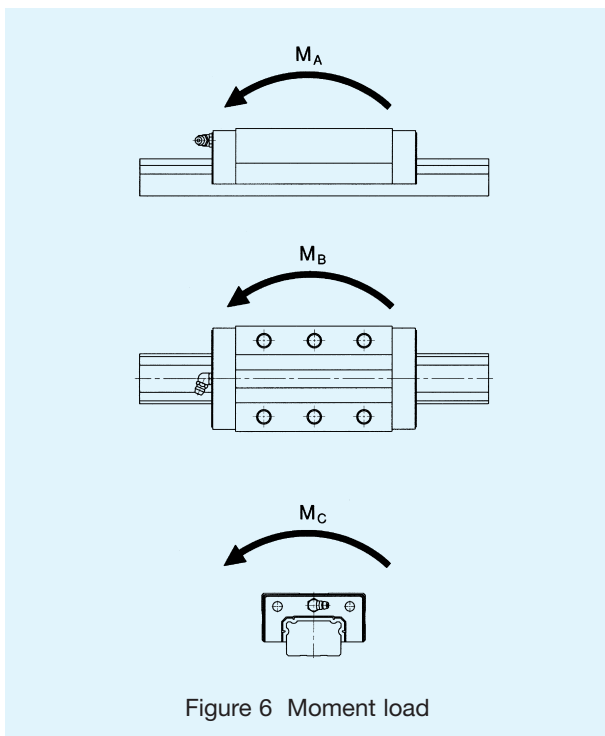

Figure 6 Moment load

Table 5 Static permissible moment of type SNR

Unit: kNm

Model No.	$M_A$	$M_B$	$M_C$
SNR25	0,55	0,29	0,68
SNR25L	0,88	0,47	0,88
SNR30	0,83	0,44	1,01
SNR30L	1,39	0,74	1,32
SNR35	1,29	0,69	1,65
SNR35H	1,29	0,69	1,65
SNR35L	2,15	1,14	2,15
SNR35LH	2,15	1,14	2,15
SNR45	2,51	1,33	3,36
SNR45H	2,51	1,33	3,36
SNR45L	4,34	2,31	4,48
SNR45LH	4,34	2,31	4,48
SNR55	4,01	2,13	5,3
SNR55H	4,01	2,13	5,3
SNR55L	6,75	3,59	6,96
SNR55LH	6,75	3,59	6,96
SNR65	6,47	3,43	8,81
SNR65L	12,31	6,55	12,33

Table 6 Static permissible moment of type SNS

Unit: kNm

Model No.	$M_A$	$M_B$	$M_C$
SNS25	0,51	0,49	0,65
SNS25L	0,83	0,79	0,84
SNS30	0,78	0,74	0,96
SNS30L	1,3	1,23	1,26
SNS35	1,21	1,15	1,56
SNS35H	1,21	1,15	1,56
SNS35L	2,01	1,92	2,05
SNS35LH	2,01	1,92	2,05
SNS45	2,35	2,23	3,21
SNS45H	2,35	2,23	3,21
SNS45L	4,07	3,88	4,28
SNS45LH	4,07	3,88	4,28
SNS55	3,75	3,57	4,96
SNS55H	3,75	3,57	4,96
SNS55L	6,33	6,02	6,51
SNS55LH	6,33	6,02	6,51
SNS65	6,06	5,76	8,24
SNS65L	11,56	10,99	11,54

## Accuracy Standard

Tables 7 shows the accuracy of types SNR/SNS. Accuracy is defined by the running parallelism and tolerances of height and width. When two or more LM blocks are installed on one rail or when two or more rails are specified as matched sets, accuracy is defined by the differences in height and width of the individual LM blocks.

### Running parallelism

For details, see General Catalog.

### Difference in height M

For details, see General Catalog.

### Difference in width W2

For details, see General Catalog.

The accuracy of types SNR/SNS is classified into normal, high, precision, super-precision and ultraprecision grades as shown in Table 7.

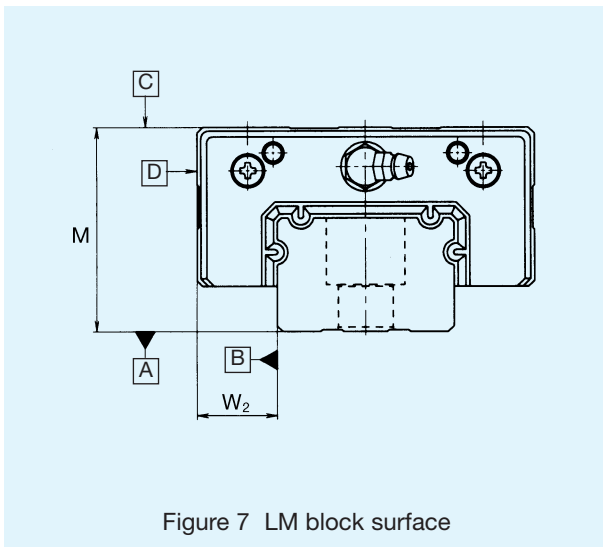

Figure 7 LM block surface

Table 7 Accuracy standard

Unit: mm

Model number	Accuracy grade	Normal	High	Precision	Super-precision	Ultra-precision
SNR	Item	No symbol	H	P	SP	UP
	Tolerance of height M	±0,1	±0,04	0 -0,04	0 -0,02	0 -0,01
	Difference in height M	0,02	0,015	0,007	0,005	0,003
	Tolerance of width W2	±0,1	±0,04	0 -0,04	0 -0,02	0 -0,01
	Difference of width W2	0,03	0,015	0,007	0,005	0,003
	Running parallelism of LM block surface C [C] with respect to surface A [A]	ΔC (Refer to Figure 8)				
SNS	Item	No symbol	H	P	SP	UP
	Tolerance of height M	0,1	0,05	0 "0,05	0 "0,03	0 "0,02
	Difference in height M	0,03	0,015	0,007	0,005	0,003
	Tolerance of width W2	0,1	0,05	0 "0,05	0 "0,03	0 "0,02
	Difference of width W2	0,03	0,02	0,01	0,007	0,005
	Running parallelism of LM block surface C [C] with respect to surface A [A]	ΔC (Refer to Figure 8)				
SNR	Item	No symbol	H	P	SP	UP
	Tolerance of height M	0,1	0,07	0 0,07	0 0,05	0 0,03
	Difference in height M	0,03	0,02	0,01	0,007	0,005
	Tolerance of width W2	0,1	0,07	0 "0,07	0 "0,05	0 "0,03
	Difference of width W2	0,03	0,025	0,015	0,010	0,007
	Running parallelism of LM block surface C [C] with respect to surface A [A]	ΔC (Refer to Figure 8)				
SNS	Item	No symbol	H	P	SP	UP
	Tolerance of height M	0,1	0,07	0 "0,07	0 "0,05	0 "0,03
	Difference in height M	0,03	0,02	0,01	0,007	0,005
	Tolerance of width W2	0,1	0,07	0 "0,07	0 "0,05	0 "0,03
	Difference of width W2	0,03	0,025	0,015	0,010	0,007
	Running parallelism of LM block surface C [C] with respect to surface A [A]	ΔC (Refer to Figure 8)				
SNR	Item	No symbol	H	P	SP	UP
	Tolerance of height M	0,1	0,07	0 "0,07	0 "0,05	0 "0,03
	Difference in height M	0,03	0,02	0,01	0,007	0,005
	Tolerance of width W2	0,1	0,07	0 "0,07	0 "0,05	0 "0,03
	Difference of width W2	0,03	0,025	0,015	0,010	0,007
	Running parallelism of LM block surface C [C] with respect to surface A [A]	ΔC (Refer to Figure 8)				
SNS	Item	No symbol	H	P	SP	UP
	Tolerance of height M	0,1	0,07	0 "0,07	0 "0,05	0 "0,03
	Difference in height M	0,03	0,02	0,01	0,007	0,005
	Tolerance of width W2	0,1	0,07	0 "0,07	0 "0,05	0 "0,03
	Difference of width W2	0,03	0,025	0,015	0,010	0,007
	Running parallelism of LM block surface C [C] with respect to surface A [A]	ΔC (Refer to Figure 8)				

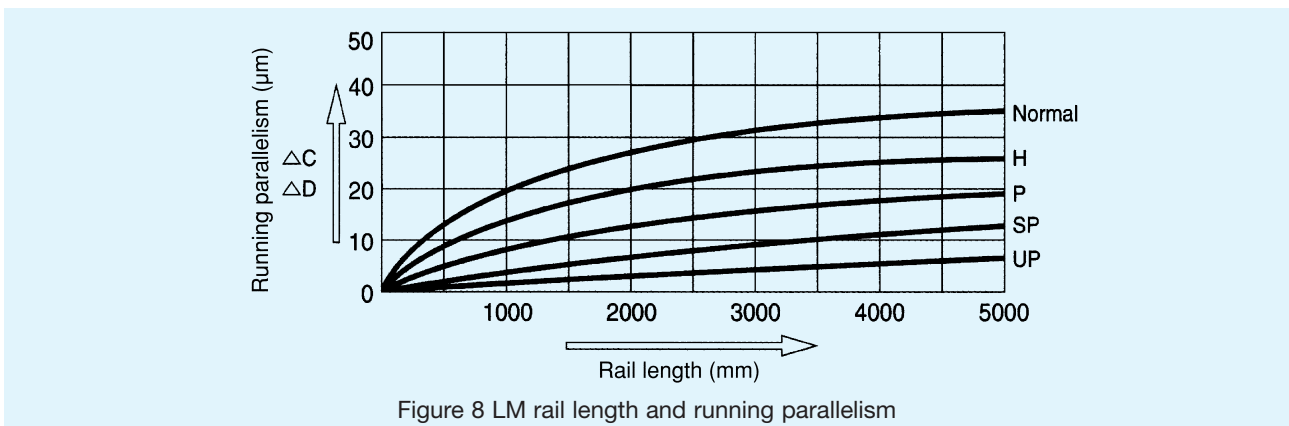

Figure 8 LM rail length and running parallelism

## Preload

Table 8 lists the preload according to the radial clearance of the types SNR-H/SNS-H and SNR/SNS. Preloaded LM Guides generally have a negative radial clearance.

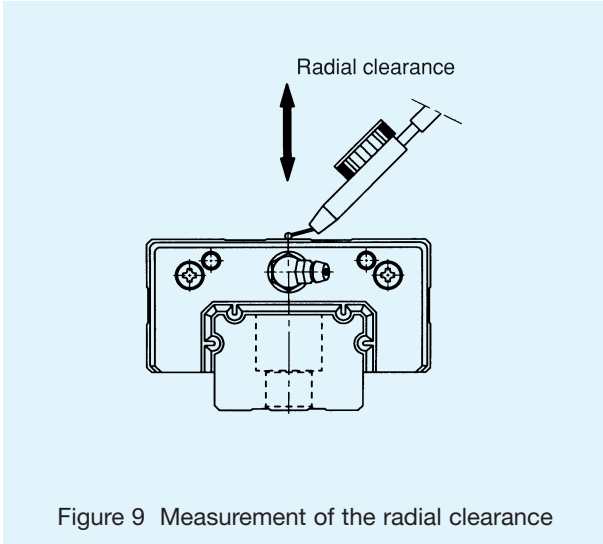

Figure 9 Measurement of the radial clearance

Table 8 Radial clearance of types SNR/SNS Unit:  $\mu\text{m}$

Symbol	Normal	Light preload	Medium preload
Model No.	—	C1	C0
SNR/SNS25	0 ~ -3	-3 ~ -6	-6 ~ -9
SNR/SNS30	0 ~ -4	-4 ~ -8	-8 ~ -12
SNR/SNS35	0 ~ -4	-4 ~ -8	-8 ~ -12
SNR/SNS45	0 ~ -5	-5 ~ -10	-10 ~ -15
SNR/SNS55	0 ~ -6	-6 ~ -11	-11 ~ -16
SNR/SNS65	0 ~ -8	-8 ~ -14	-14 ~ -20

Note 1: No symbol is necessary for normal clearance. Add the corresponding symbols to the model number if C0 or C1 clearance is required. See the descriptions for the model number coding.

## Model Number Coding

**SNR45 LRH 2 QZ SS C0 + 1200L P Z - II <sup>1)</sup>**

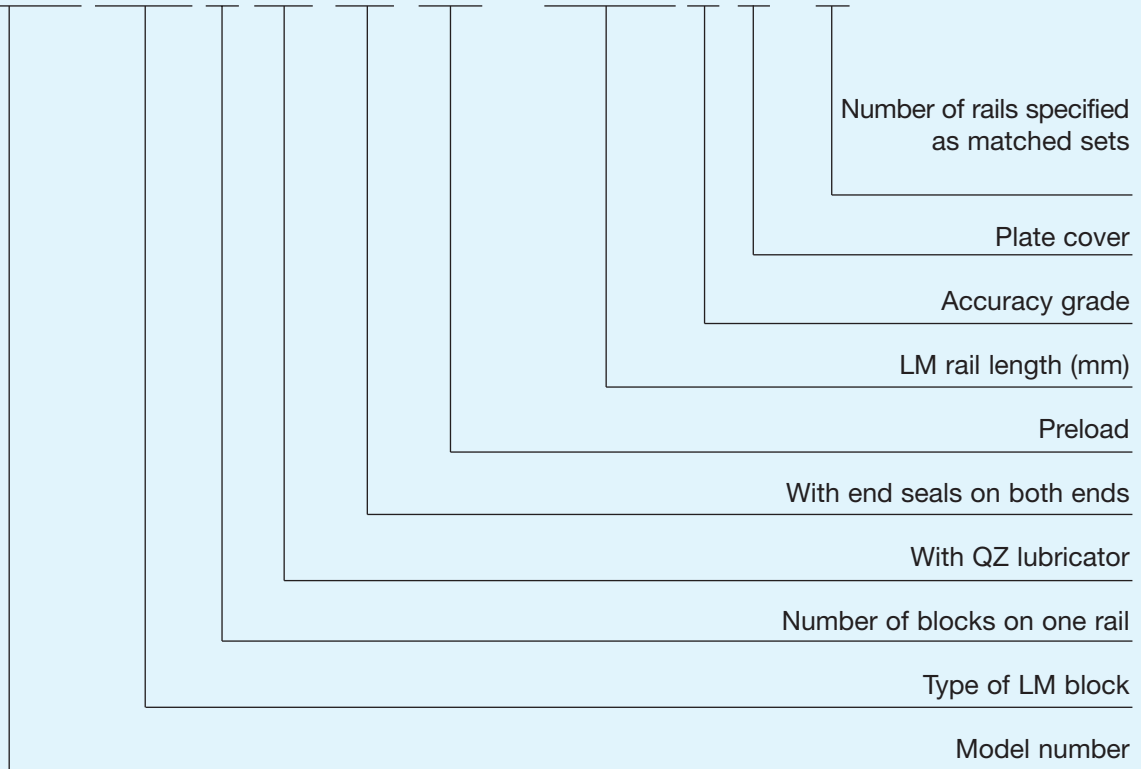

<sup>1)</sup>The symbol "II" indicates the projected mounting design with two parallel LM rails.

## Options

A variety of accessories are available for types SNR/SNS.  
These can be selected depending on the customer's specification.

### Accessories

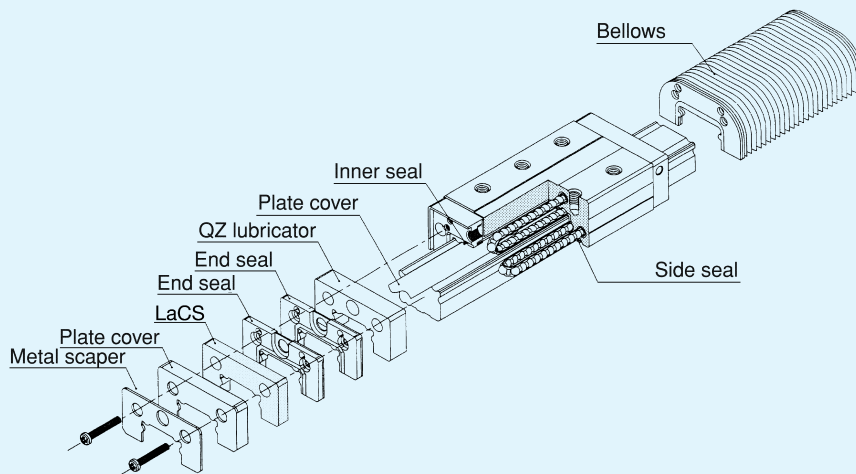
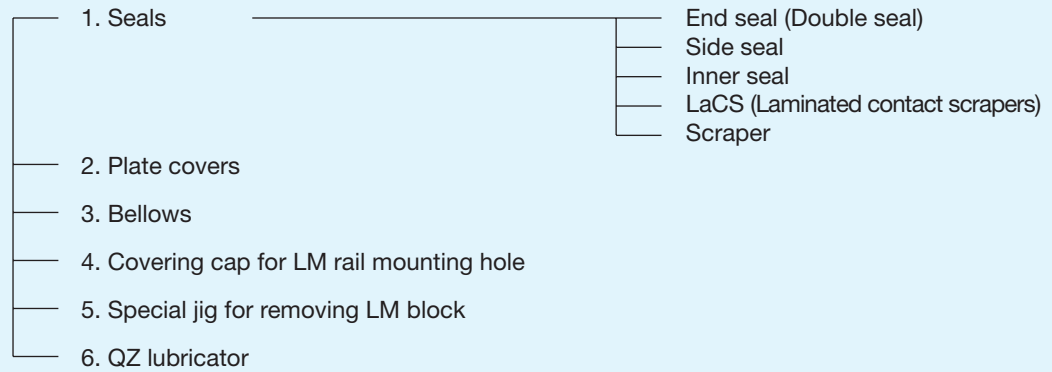

Figure 10 Possible sealings for types SNR and SNS

## 1. Seal

### End Seal

Types SNR/SNS are provided with end seals as a standard feature.

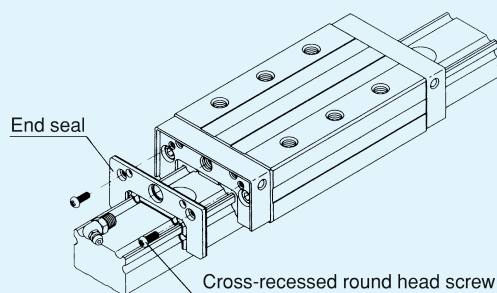

Figure 11

### Double seals

Double seals for better contamination protection capability are available for types SNR/SNS.

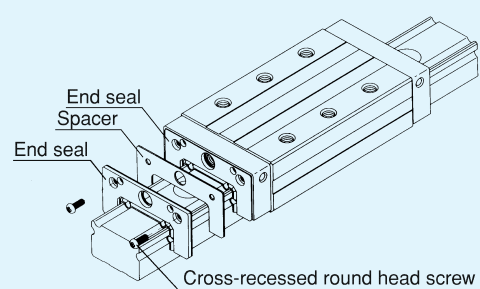

Figure 12

**Side seals**

To prevent the contamination from under the LM block, side seals are available for types SNR/SNS.

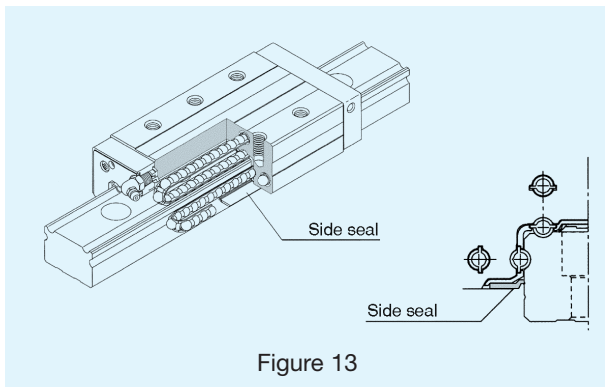

Figure 13

**LaCS (Laminated contact scrapers)**

The surface-to-surface contact protects the rail from microscopic foreign matter far more effectively than conventional metal scrapers can. Siehe Katalog No. 247-G.

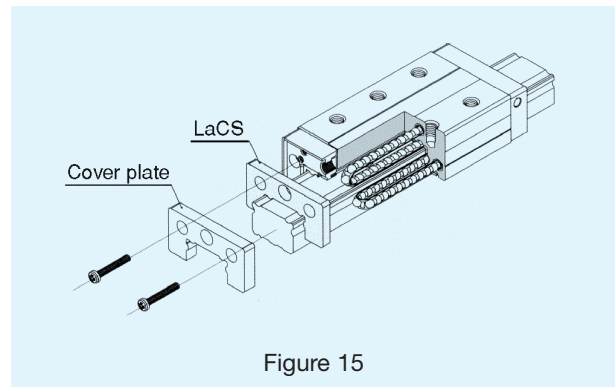

Figure 15

**Inner seals**

Inner seals to be installed inside the block are available for types SNR/SNS.

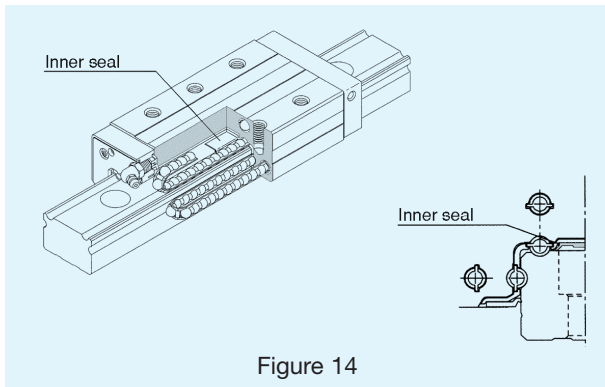

Figure 14

**Metal scrapers**

Metal scraper is used to remove relatively large or hard particles of foreign matter adhering to the LM rail.

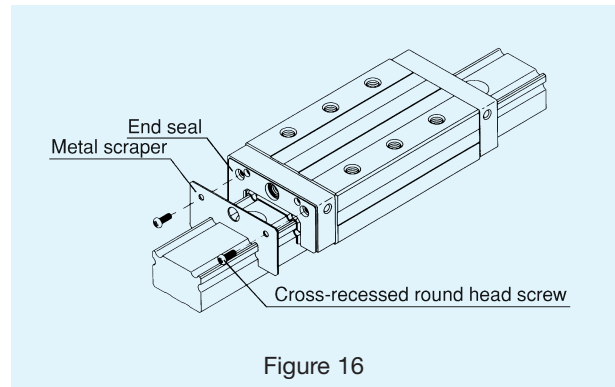

Figure 16

**Symbols for contamination protection system**

When contamination protection is required, specify according to code shown.

The entire block length may vary depending on the type used. Add the increased dimensions (refer to Table 9) to the corresponding "L" value shown in the dimension tables.

Symbol	Symbol Protection system
UU	With end seal (on both ends)
SS	With end seals, side seals and inner seals
ZZ	With end seals, side seals, inner seals and metal scrapers
DD	With double seals, side seals and inner seals
KK	With double seals, side seals, inner seals and metal scrapers
ZZHH	With end seals, side seals, inner seals, metal scrapers and LaCS
KKHH	With double seals, side seals, inner seals, metal scrapers and LaCS

Table 9 Variation of the LM block length according to the mounted seals

Unit: mm

Model No.	—	UU	SS	DD	ZZ	KK	ZZHH	KKHH
SNR/SNS25	—	—	—	7,4	6,2	13,8	22,5	30,5
SNR/SNS30	—	—	—	9,0	6,4	15,4	26,0	35,5
SNR/SNS35	—	—	—	10,2	7,6	17,8	28,0	38,0
SNR/SNS45	—	—	—	10,2	8,4	18,6	32,0	42,5
SNR/SNS55	—	—	—	10,0	8,4	18,6	32,5	42,5
SNR/SNS65	—	—	—	10,6	8,2	18,8	43,5	47,0

## 2. Plate Covers

Film-thin stainless steel (SUS304) plate covers are available for types SNR/SNS. The plate covers are essential contamination protection devices for machine tools. The plate cover is installed over the rail installation holes and improves the seal contact. It prevents the entry of coolant or machine chips into the block. This cannot be achieved by conventional means. The stopper is used to install the plate cover.

### Installing the plate cover:

1. Attach slide pieces to the cover plate. Place the cover plate between a slide piece and a fixing plate, with the slide piece chamfer facing out. Attach the fixing plate to the slide piece using countersunk head screws.

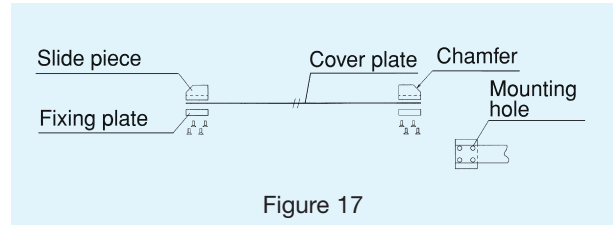

Figure 17

2. Remove the LM block from the LM rail. Mount the fixing jigs to both ends of the LM rail. Locate the positions of the fixing-jig mounting holes and attach the fixing jig using hexagon socket head cap screws.

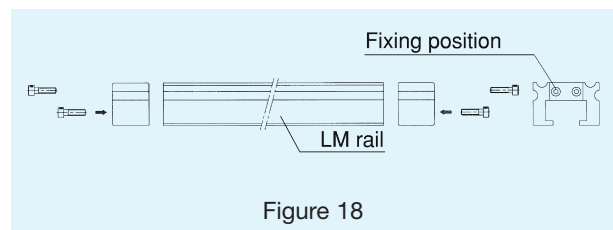

Figure 18

3. Temporarily fix one slide piece. Insert one slide piece into the fixing jig. Install it at the end of the LM rail using a tension-adjustment bolt. Screw the bolt in until its head disappears into the fixing jig.

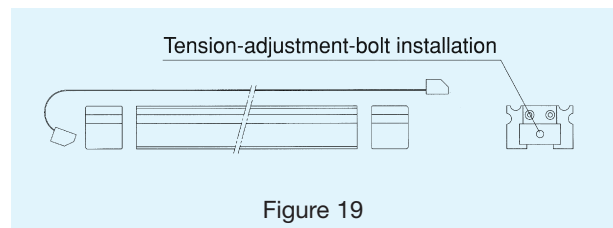

Figure 19

4. Temporarily fix the other slide piece. Perform the same steps to temporarily fix the other slide piece.

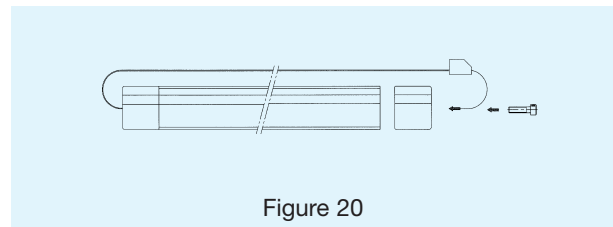

Figure 20

5. Apply tension to the plate cover. Tighten the tension-adjustment bolts at both ends of the LM rail so that the tension is well balanced. At this time, care must be taken to ensure that there is no significant difference between the dimension H and the dimension H' illustrated in figure 21, as the tightening margin on one end of the LM rail may be eliminated.

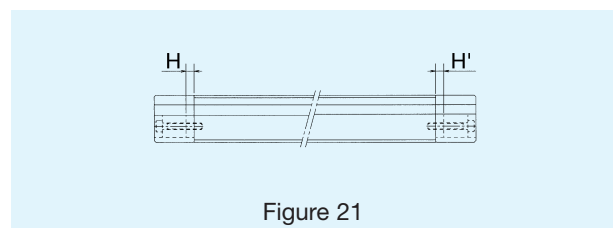

Figure 21

6. Insert the LM block into the LM rail. Locate the datum planes of the LM rail and the LM block, and insert the LM block into the LM rail through the use of the insertion jig.

- Note:**
- 1. When removing or inserting an LM block, be extremely careful not to allow the balls to fall off.
  - 2. As the plate cover consists of ultra-thin stainless sheet steel (SUS304), be extremely careful when handling it. Never bend or otherwise deform it.
  - 3. Plate covers are not available for both type SNR and type SNS 35 ~ 65.



### 3. Bellows

#### Bellows

Bellows may be installed where coolant or a similar substance is likely to enter.

#### Metal-telescopic cover

A telescopic cover can be installed over the bellows as shown in Figure 22.

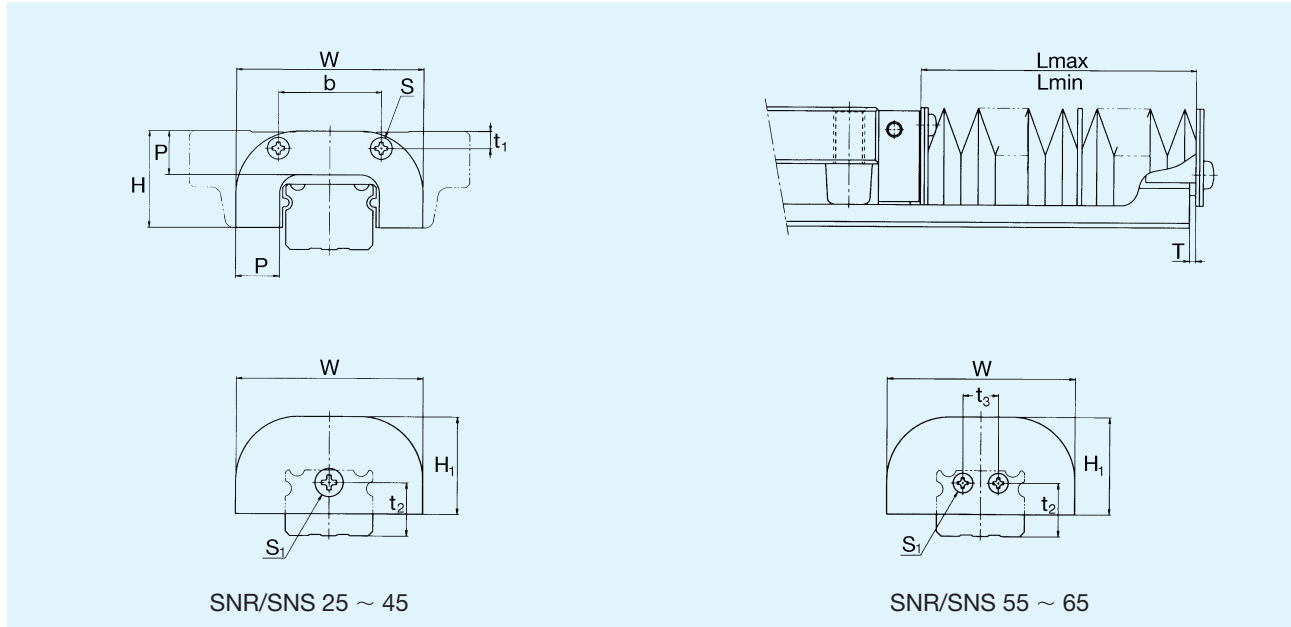

Table 10 Dimension table for bellows

Unit: mm

Model number	W	H	H <sub>1</sub>	P	Major dimensions					LM block mounting bolt S × length under head	LM block mounting bolt S <sub>1</sub> × length under head	T	A L <sub>max</sub> L <sub>min</sub>	Applicable models
					b	t <sub>1</sub>	t <sub>2</sub>	t <sub>3</sub>						
JSN25	50	25,5	24,5	10	26,6	4,6	13	—	M3 × 5	M4 × 4	1,5	7	SNR/SNS25	
JSN30	60	31	30	14	34	5,5	16,5	—	M4 × 8	M4 × 4	1,5	9	SNR/SNS30	
JSN35	70	35	34	15	36	6	20	—	M4 × 8	M5 × 4	2	10	SNR/SNS35	
JSN45	86	40,5	39,5	17	47	6,5	23,5	—	M5 × 10	M5 × 4	2	10	SNR/SNS45	
JSN55	100	49	48	19,5	54	10	30,6	18	M5 × 10	M5 × 4	2	13	SNR/SNS55	
JSN65	126	60	59	22	64	13,5	36,1	20	M6 × 12	M6 × 5	3,2	13	SNR/SNS65	

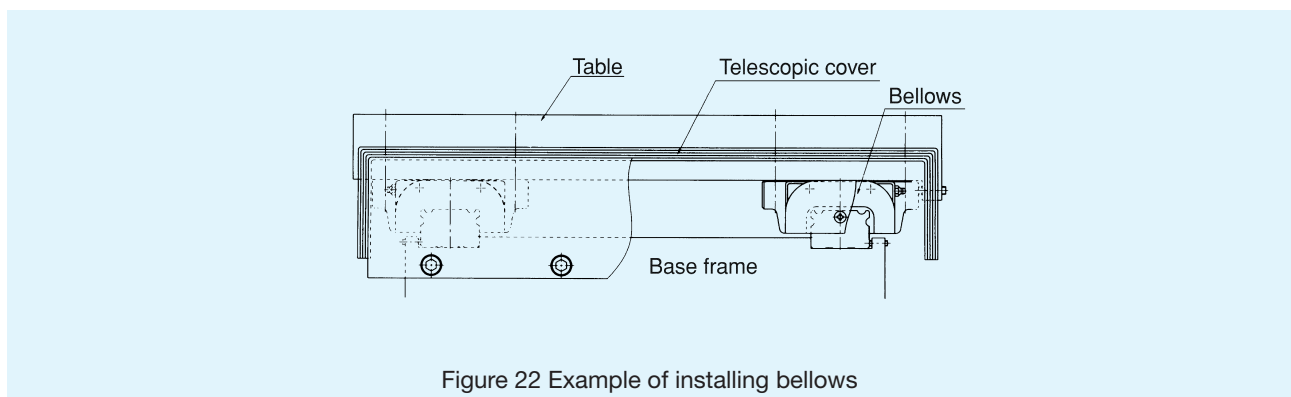

Figure 22 Example of installing bellows

#### Model Number Coding for Bellows

JSN25 - 60/420

Bellows dimension      Folded length  
 Extended length  
 Model number ... for SNR 25

## 4. C Cap for LM Rail Mounting Hole

### C cap

When chips or foreign materials enter the LM rail mounting holes of the LM Guide, they may enter the LM block. Contaminants can be prevented from entering the LM block by covering those LM rail mounting holes with special caps and ensuring that the caps are flush with the top surface of the LM rail. The special cap type C for LM rail mounting holes is made of a special synthetic resin with a high degree of oilproofing and wear resistance for excellent durability. Special caps for hexagon socket head set screws M5-M16 are kept in stock as standard equipment (Table 11). When it is necessary to order special caps, specify them using the nominal numbers in the dimension table.

To insert a special cap in a mounting hole, apply a flat metal piece to the cap, as shown in Figure 23, and then gently tap the metal until the cap becomes flush with the top of the LM rail.

Table 11 C cap

Unit: mm

C cap type	Screw	Main dimensions		Applicable number
		D	H	
C 5	M 5	9,8	2,4	SNR/SNS25
C 6	M 6	11,4	2,7	SNR/SNS30
C 8	M 8	14,4	3,7	SNR/SNS35
C 12	M 12	20,5	4,7	SNR/SNS45
C 14	M 14	23,5	5,7	SNR/SNS55
C 16	M 16	26,5	5,7	SNR/SNS65

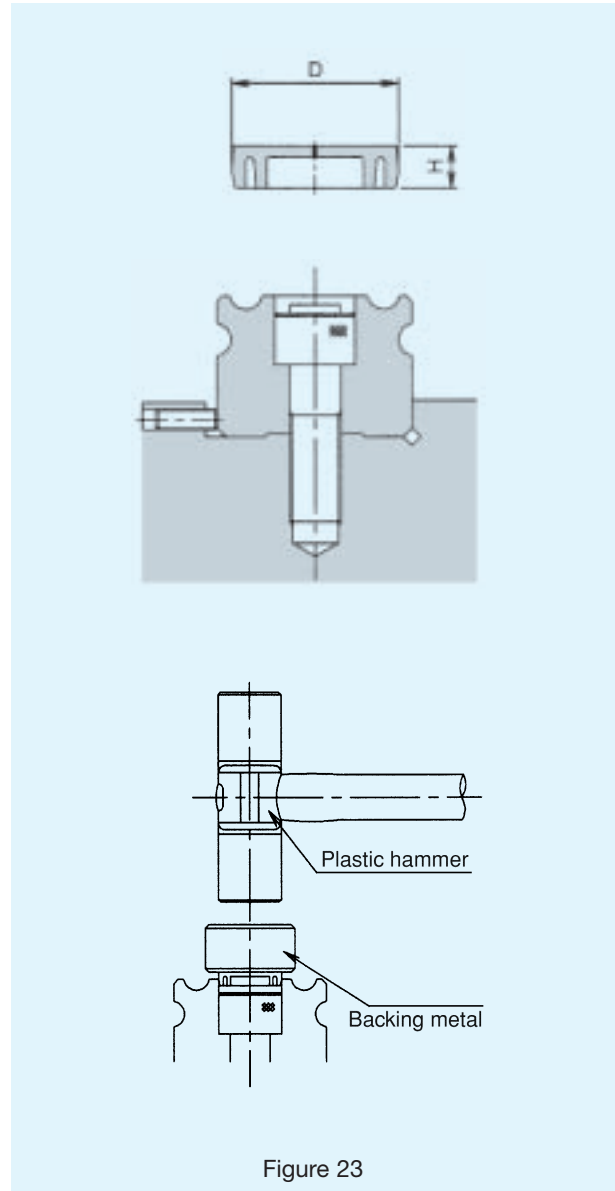

Figure 23

## 5. Special Insertion Jig

Types SNR/SNS have balls separated by the ball cage. This structure prevents the balls from dropping out when the block is removed from the rail. However, when the block is inserted onto the rail without being properly parallel to the raceway, the ball may drop out or the ball cage may be damaged. We recommend that the special THK insertion jig be used.

(Always use a special insertion jig for parts to which a preload is applied.)

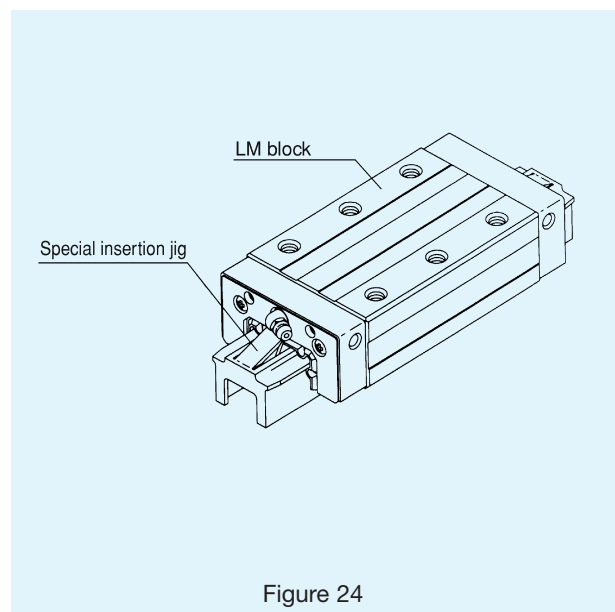

Figure 24

## 6. QZ Lubricator

THK has developed the QZ lubricator containing a fiber net (occluding element) with high oil content in order to meet the requirement for long-term maintenance-free technology in LM Guide lubrication.

### Maintenance intervals can be greatly extended

Normally in LM systems, a (very) small amount of oil is lost as the machine runs. By mounting the QZ lubricator on the LM block, lost oil is automatically replaced, greatly extending maintenance intervals.

### QZ lubricator is environmentally conscious

Because QZ lubricator uses a high-density fiber net to supply the appropriate amount of oil to the appropriate positions, there is no excess oil, making it an environmentally conscious design.

### The best oil for each application can be used

QZ lubricator permits the use of the most suitable oil for LM Guide. QZ lubricator is available as a standard option for types SNR/SNS.

See THK Catalog No. 230-E for details.

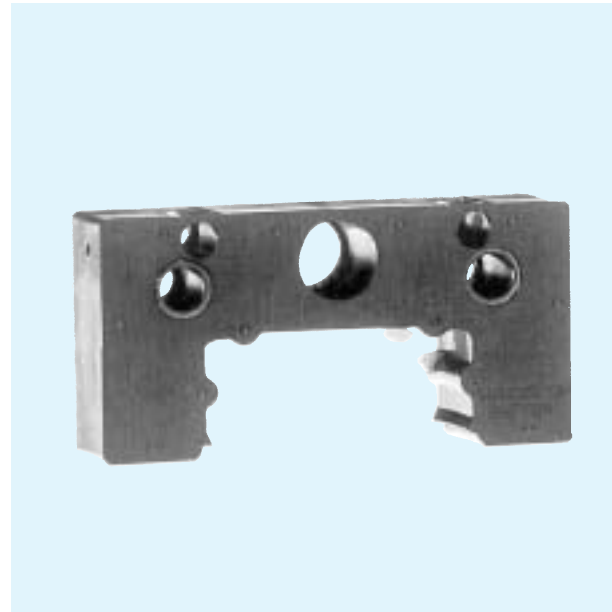
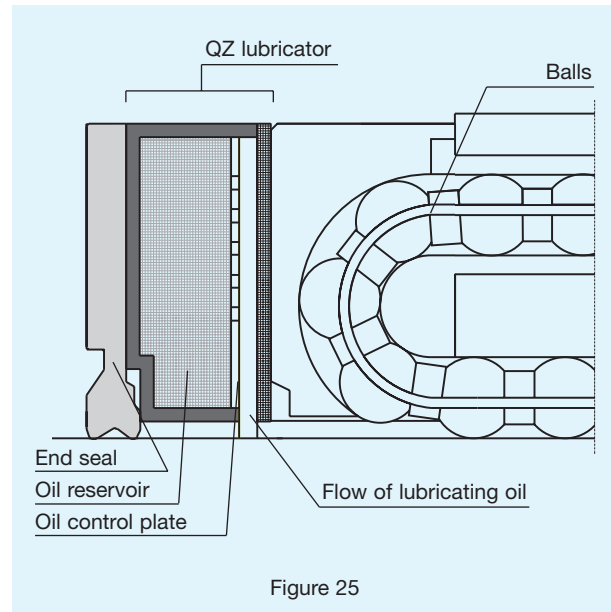

## Mounting Instruction

### Shoulder height and bottom corner of installation surfaces

For installation, recommended shoulder height is listed in Table 12. Also, bottom corner of shoulder should have relief or radius less than  $r$  in table 12.

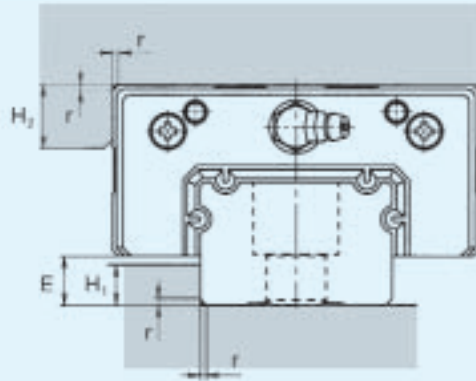

Figure 26

Table 12 Heights and radius of bottom corner

Unit: mm

Model number	Radius of bottom corner $r_{(max.)}$	Shoulder height accommodating LM rail $H_1$	Shoulder height accommodating LM block $H_2$	E
SNR/SNS25	0,5	5	5	5,5
SNR/SNS30	1,0	5	5	7
SNR/SNS35	1,0	6	6	9
SNR/SNS45	1,0	8	8	11,5
SNR/SNS55	1,5	10	10	14
SNR/SNS65	1,5	10	10	15

### Seal Resistance

Regarding to types SNR/ SNS with "SS" seals (end seals and side seals on both ends), Table13 shows the values of maximum seal resistance for one LM block.

Table 13 Seal resistance

Unit: N

Model number	Seal resistance
SNR/SNS25	8
SNR/SNS30	14
SNR/SNS35	14
SNR/SNS45	16
SNR/SNS55	20
SNR/SNS65	25

## Standard and Maximum Lengths of LM Rails

Table 14 lists the standard and maximum LM rail lengths of types SNR/SNS. If a rail longer than the corresponding maximum length is specified, the rail will be in two or more sections.

If a special length is required, G dimension listed in the table is recommended. If the G dimension is too long, it makes the rail ends insecure which may adversely affect accuracy. When two or more rails are to be connected, be sure to inform **THK** of the overall LM rail length.

The rails will be machined simultaneously in order to give precise joints.

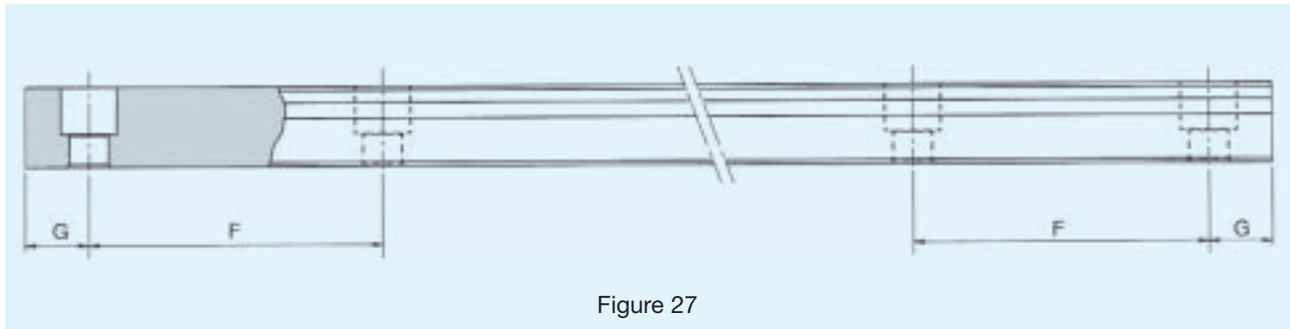

Figure 27

Table 14 Standard and maximum LM rail lengths of types SNR/SNS

Unit: mm

Model number	SNR/SNS25	SNR/SNS30	SNR/SNS35	SNR/SNS45	SNR/SNS55	SNR/SNS65
Standard LM rail length (L <sub>0</sub> )	230	280	280	570	780	1270
	270	360	360	675	900	1570
	350	440	440	780	1020	2020
	390	520	520	885	1140	2620
	470	600	600	990	1260	
	510	680	680	1095	1380	
	590	760	760	1200	1500	
	630	840	840	1305	1620	
	710	920	920	1410	1740	
	750	1000	1000	1515	1860	
	830	1080	1080	1620	1980	
	950	1160	1160	1725	2100	
	990	1240	1240	1830	2220	
	1070	1320	1320	1935	2340	
	1110	1400	1400	2040	2460	
	1190	1480	1480	2145	2580	
	1230	1560	1560	2250	2700	
	1310	1640	1640	2355	2820	
	1350	1720	1720	2460	2940	
	1430	1800	1800	2565	3060	
	1470	1880	1880	2670		
	1550	1960	1960	2775		
	1590	2040	2040	2880		
	1710	2200	2200	2985		
1830	2360	2360	3090			
1950	2520	2520				
2070	2680	2680				
2190	2840	2840				
2310	3000	3000				
2430						
2470						
F	40	80	80	105	120	150
G	15	20	20	22,5	30	35
Maximum length	2500	3000	3000	3090	3060	3000

Note: Maximum length differs depending on accuracy grades. If a single-piece LM rail exceeding the corresponding maximum length listed in Table 14 is desired, please contact **THK**.

# SNR/SNS

CAGED BALL LM GUIDE

Type SNR/SNS-RH (Heavy load type)  
Type SNR/SNS-LRH (Ultra heavy load type)

Compact LM block with fitting measurement according to DIN 645

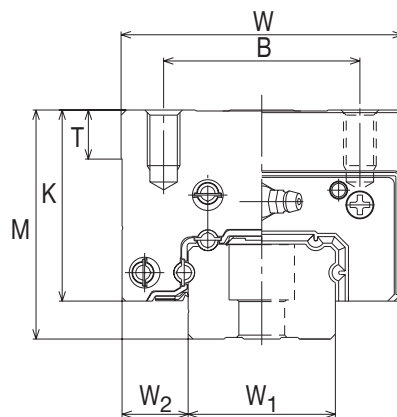

Model number <sup>1)</sup>	Main dimensions			LM block dimensions										
	Height	Width	Length	B	C	S × l	L <sub>1</sub>	T	K	N	N <sub>1</sub>	E	E <sub>1</sub>	d <sub>0</sub>
	M	W	L											
SNR/SNS35RH SNR/SNS35LRH	55	70	109,5 135	50	50 72	M8 × 12	79 104,5	12	46	19	19	9	6	5,2
SNR/SNS45RH SNR/SNS45LRH	70	86	138,2 171	60	60 80	M10 × 17	105 137,8	15	58,4	28	26	14	8,5	5,2
SNR/SNS55RH SNR/SNS55LRH	80	100	163,3 200,5	75	75 95	M12 × 18	123,6 160,8	18	66	28	27	13	10	5,2

<sup>1)</sup> See page 11 for the model number coding.

<sup>2)</sup> See page 19 for the standard LM rail lengths.

<sup>3)</sup> See page 9 for static permissible moment  $M_A$ ,  $M_B$  und  $M_C$ .

# SNR/SNS

CAGED BALL LM GUIDE

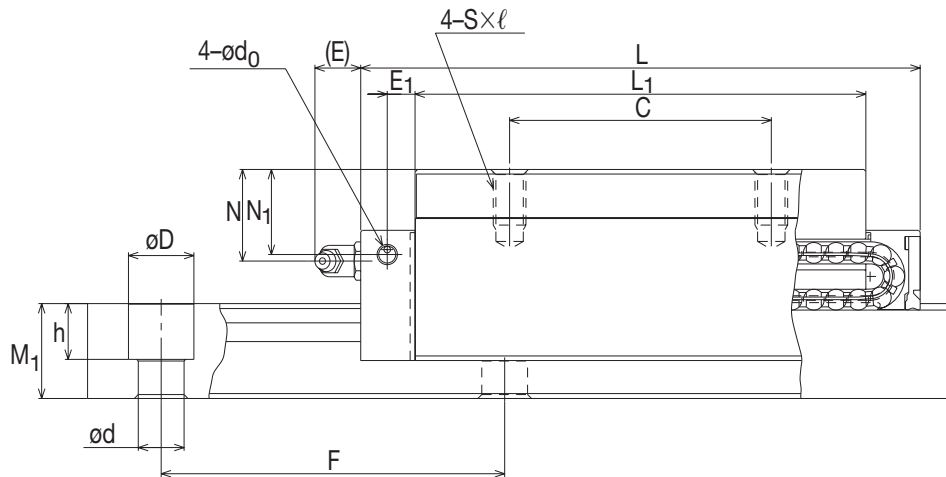

Unit: mm

Grease fitting	LM rail dimensions <sup>2)</sup>					Basic load rating <sup>3)</sup>				Mass	
	Width	Height	Pitch	d × D × h	SNR	SNS	SNR	SNS	LM block [kg]	LM rail [kg/m]	
	$W_1 \begin{smallmatrix} 0 \\ -0,05 \end{smallmatrix}$				$W_2$	C	C	$C_0$			$C_0$
B—M6F	34	18	24,5	80	9 × 14 × 12	89,7 108	68,7 82,7	144 188	110 144	1,5 2,0	6,2
B—PT1/8	45	20,5	29	105	14 × 20 × 17	132 161	101 123	216 288	167 222	3,2 4,1	9,8
B—PT1/8	53	23,5	36,5	120	16 × 23 × 20	177 214	136 164	292 383	225 295	4,7 6,2	14,5

# SNR/SNS

CAGED BALL LM GUIDE

Type SNR/SNS-CH (Heavy load type)  
Type SNR/SNS-LCH (Ultra heavy load type)

Flange LM block with fitting measurement according to DIN 645

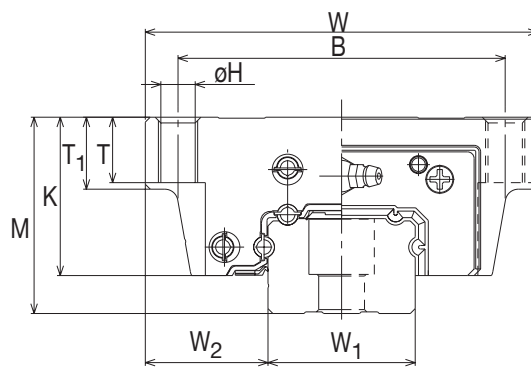

Model number <sup>1)</sup>	Main dimensions			LM block dimensions												
	Height	Width	Length	B	C	S	H	L <sub>1</sub>	T	T <sub>1</sub>	K	N	N <sub>1</sub>	E	E <sub>1</sub>	d <sub>0</sub>
	M	W	L													
SNR/SNS35CH	48	100	109,5	82	62	M10	8,5	79	16	20	39	12	12	9	6	5,2
SNR/SNS35LCH			135													
SNR/SNS45CH	60	120	138,2	100	80	M12	10,5	105	20	22	48,4	18	16	14	8,5	5,2
SNR/SNS45LCH			171													
SNR/SNS55CH	70	140	163,3	116	95	M14	12,5	123,6	22	24	56	18	17	13	10	5,2
SNR/SNS55LCH			200,5													

<sup>1)</sup> See page 11 for the model number coding.

<sup>2)</sup> See page 19 for the standard LM rail lengths.

<sup>3)</sup> See page 9 for static permissible moment  $M_A$ ,  $M_B$  und  $M_C$ .

# SNR/SNS

CAGED BALL LM GUIDE

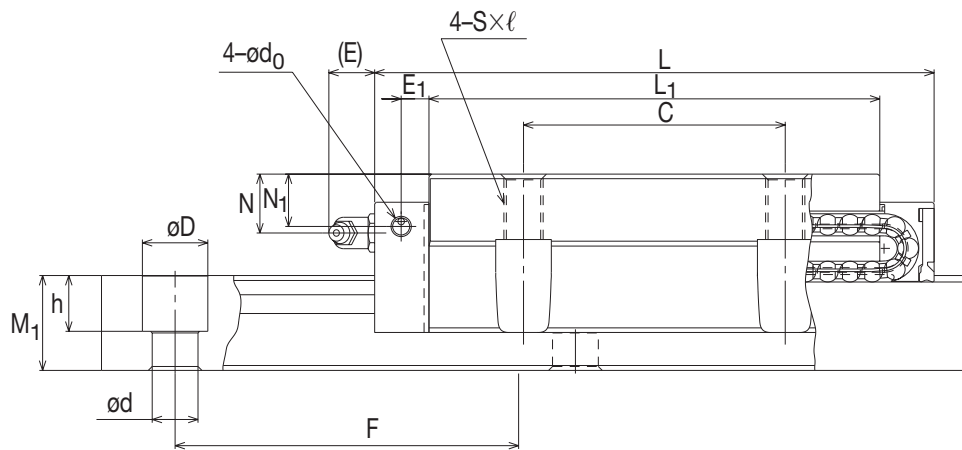

Unit: mm

Grease fitting	LM rail dimensions <sup>2)</sup>					Basic load rating <sup>3)</sup>				Mass	
	Width	Height	Pitch	d × D × h	SNR	SNS	SNR	SNS	LM block [kg]	LM rail [kg/m]	
	$W_1 \begin{smallmatrix} 0 \\ -0,05 \end{smallmatrix}$				$W_2$	C	C	$C_0$			$C_0$
B—M6F	34	33	24,5	80	9 × 14 × 12	89,7 108	68,7 82,7	144 188	110 144	1,7 2,2	6,2
B—PT1/8	45	37,5	29	105	14 × 20 × 17	132 161	101 123	216 288	167 222	3,0 4,2	9,8
B—PT1/8	53	43,5	36,5	120	16 × 23 × 20	177 214	136 164	292 383	225 295	4,4 6,5	14,5

# SNR/SNS

CAGED BALL LM GUIDE

Type SNR/SNS-R (Heavy load type)  
Type SNR/SNS-LR (Ultra heavy load type)

## Compact LM block

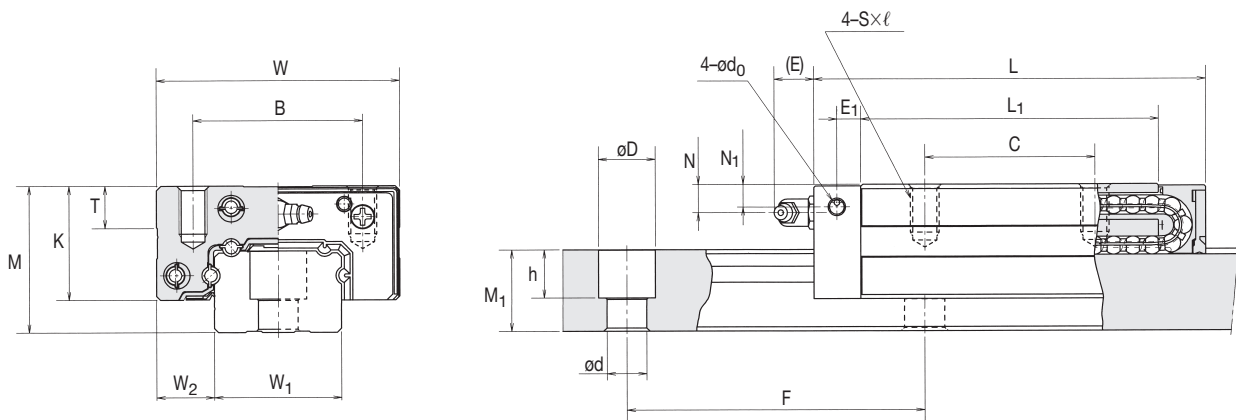

SNR/SNS-R

Model number <sup>1)</sup>	Main dimensions			LM block dimensions										
	Height	Width	Length	B	C	S × ℓ	L <sub>1</sub>	T	K	N	N <sub>1</sub>	E	E <sub>1</sub>	d <sub>0</sub>
	M	W	L											
SNR/SNS25R	31	50	83	32	35	M6 × 8	62,4	10	25,5	7	6	10	4	3,9
SNR/SNS25LR			102											
SNR/SNS30R	38	60	98	40	40	M8 × 10	72,1	10	31	7	7	10	6,5	3,9
SNR/SNS30LR			120,5											
SNR/SNS35R	44	70	109,5	50	50	M8 × 12	79	12	35	8	8	9	6	5,2
SNR/SNS35LR			135											
SNR/SNS45R	52	86	138,2	60	60	M10 × 17	105	15	40,4	10	8	14	8,5	5,2
SNR/SNS45LR			171											
SNR/SNS55R	63	100	163,3	65	75	M12 × 18	123,6	18	49	11	10	13	10	5,2
SNR/SNS55LR			200,5											
SNR/SNS65R	75	126	186	76	70	M16 × 20	143,6	22	60	16	15	13,5	9	8,2
SNR/SNS65LR			246											

<sup>1)</sup> See page 11 for the model number coding.

<sup>2)</sup> See page 19 for the standard LM rail lengths.

<sup>3)</sup> See page 9 for static permissible moment  $M_A$ ,  $M_B$  und  $M_C$ .

# SNR/SNS

## CAGED BALL LM GUIDE

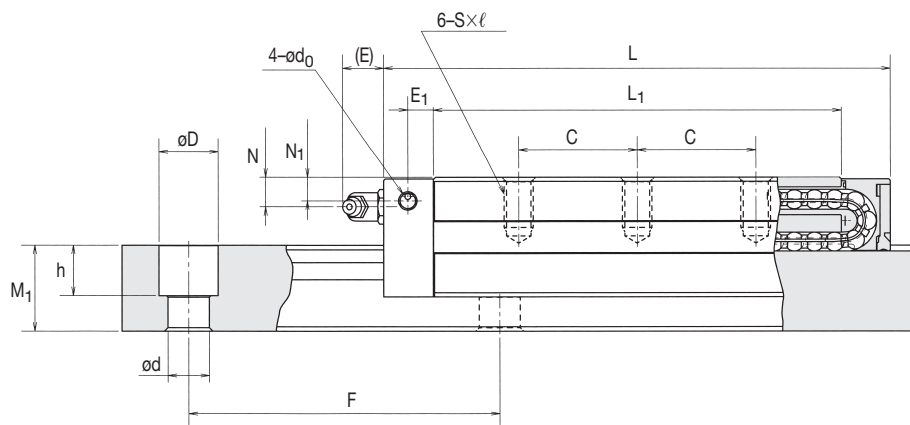

SNR/SNS-LR

Unit: mm

Grease fitting	LM rail dimensions <sup>2)</sup>					Basic load rating <sup>3)</sup>				Mass	
	Width	Height	Pitch	d × D × h	SNR	SNS	SNR	SNS	LM block [kg]	LM rail [kg/m]	
	$W_1 \begin{smallmatrix} 0 \\ -0,05 \end{smallmatrix}$				$W_2$	$M_1$	$F$	C [kN]			C [kN]
B—M6F	25	12,5	17	40	6 × 9,5 × 8,5	48,3 57,1	37,0 43,7	79 101	61 78	0,4 0,6	3,1
B—M6F	28	16	21	80	7 × 11 × 9	68,0 81,1	52,1 62,1	106 138	81 106	0,7 0,9	4,4
B—M6F	34	18	24,5	80	9 × 14 × 12	89,7 108	68,7 82,7	144 188	110 144	1,0 1,4	6,2
B—PT1/8	45	20,5	29	105	14 × 20 × 17	132 161	101 123	216 288	167 222	1,9 2,4	9,8
B—PT1/8	53	23,5	36,5	120	16 × 23 × 20	177 214	136 164	292 383	225 295	3,1 4,0	14,5
B—PT1/8	63	31,5	43	150	18 × 26 × 22	260 340	199 260	409 572	315 441	5,6 8,0	20,5

3D CAD at [www.thk.de](http://www.thk.de)

# SNR/SNS

CAGED BALL LM GUIDE

Type SNR/SNS-C (Heavy load type)  
Type SNR/SNS-LC (Ultra heavy load type)

## Flange LM block

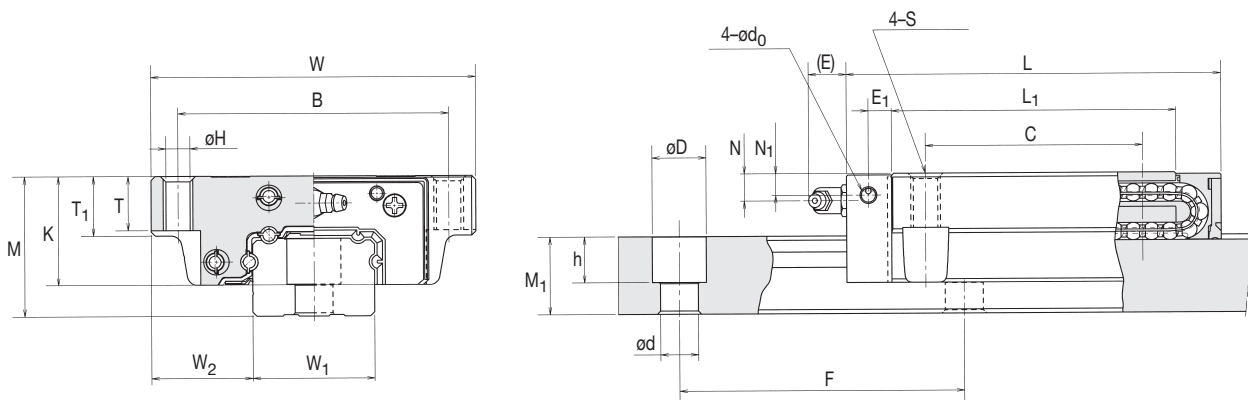

SNR/SNS-C

Model number <sup>1)</sup>	Main dimensions			LM block dimensions												
	Height	Width	Length	B	C	S	H	L <sub>1</sub>	T	T <sub>1</sub>	K	N	N <sub>1</sub>	E	E <sub>1</sub>	d <sub>0</sub>
	M	W	L													
SNR/SNS25C	31	72	84	59	45	M 8	6,8	62,4	12	16	25,5	7	6	10	4	3,9
SNR/SNS25LC			103		22,5			81,6								
SNR/SNS30C	38	90	98	72	52	M10	8,5	72,1	14	18	31	7	7	10	6,5	3,9
SNR/SNS30LC			120,5		26			94,6								
SNR/SNS35C	44	100	109,5	82	62	M10	8,5	79	16	20	35	8	8	9	6	5,2
SNR/SNS35LC			135		31			104,5								
SNR/SNS45C	52	120	138,2	100	80	M12	10,5	105	20	22	40,4	10	8	14	8,5	5,2
SNR/SNS45LC			171		40			137,8								
SNR/SNS55C	63	140	163,3	116	95	M14	12,5	123,6	22	24	49	11	10	13	10	5,2
SNR/SNS55LC			200,5		47,5			160,8								
SNR/SNS65C	75	170	186	142	110	M16	14,5	143,6	25	28	60	16	15	13,5	9	8,2
SNR/SNS65LC			246		55			203,6								

<sup>1)</sup> See page 11 for the model number coding.

<sup>2)</sup> See page 19 for the standard LM rail lengths.

<sup>3)</sup> See page 9 for static permissible moment  $M_A$ ,  $M_B$  und  $M_C$ .

# SNR/SNS

CAGED BALL LM GUIDE

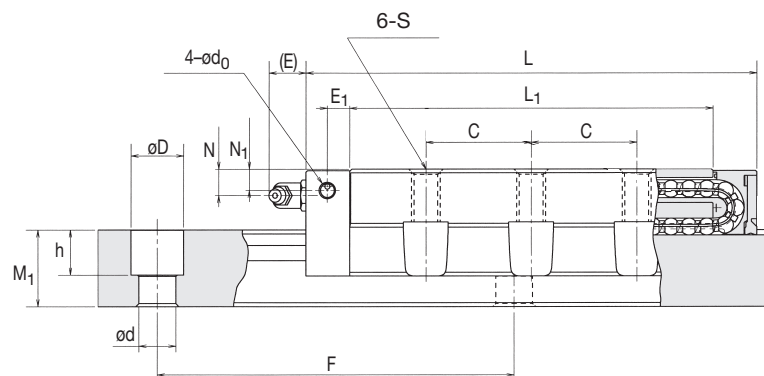

SNR/SNS-LC

Unit: mm

Grease fitting	LM rail dimensions <sup>2)</sup>					Basic load rating <sup>3)</sup>				Mass	
	Width	Height	Pitch	d × D × h	SNR	SNS	SNR	SNS	LM block [kg]	LM rail [kg/m]	
	$W_1 \begin{smallmatrix} 0 \\ -0,05 \end{smallmatrix}$				$W_2$	C	C	$C_0$			$C_0$
B—M6F	25	23,5	17	40	6 × 9,5 × 8,5	48,3	37,0	79	61	0,6	3,1
						57,1	43,7	101	78	0,8	
B—M6F	28	31	21	80	7 × 11 × 9	68,0	52,1	106	81	1,0	4,4
						81,1	62,1	138	106	1,3	
B—M6F	34	33	24,5	80	9 × 14 × 12	89,7	68,7	144	110	1,5	6,2
						108	82,7	188	144	2,0	
B—PT1/8	45	37,5	29	105	14 × 20 × 17	132	101	216	167	2,3	9,8
						161	123	288	222	3,4	
B—PT1/8	53	43,5	36,5	120	16 × 23 × 20	177	136	292	225	3,6	14,5
						214	164	383	295	5,5	
B—PT1/8	63	53,5	43	150	18 × 26 × 22	260	199	409	315	7,4	20,5
						340	260	572	441	10,5	

3D CAD at [www.thk.de](http://www.thk.de)



## Notes on use

### • Precautions in handling the LM block

The LM block includes precision mold resin. When it is dropped or struck, it may be damaged. Please take great care in handling the LM block.

### • Using holes on the sides of the LM block for lubrication nipples

When it is necessary to use holes on the sides of the LM block for attachment of lubrication nipples, please contact THK. THK will install nipples on the LM block. (Holes are not made all the way through to prevent foreign materials from entering.) These holes are for lubrication nipples only. Use of these holes for other purpose may break end plate.

### • Reinstalling the LM block

When the LM block is removed from the LM rail and then reinstalled, please insert it very carefully and correctly.

\*\*For reinstallation, we recommend that a special insertion jig is to be used. Please contact THK upon the use of jig.

### • Coolant

When the LM block is used in an environment in which some coolant may enter the LM block, some types of coolant may adversely affect the functions of the LM block. Please contact THK when selecting a coolant.

### • Operating temperature range

The LM block is made from special resin. Do not use it above 80°C.

### • Lubrication

Ordinary grease may not be utilized when the system is used in a special environment such as an area subject to extremes of temperature or continuous vibration, a clean room, or a vacuum environment. If the system is to be used in a special environment, please contact THK.

Specifications are subject to change without notice.

06/2003 Printed in Belgium

## Sales Offices

### U.K.

**THK U.K.**  
26 Alston Drive  
Bradwell Abbey  
Milton Keynes,  
MK13 9HA  
Tel. (0 19 08) 22 21 59  
Fax (0 19 08) 22 21 61  
www.thk.co.uk  
info.mks@thk.co.uk

### Switzerland

**Bachofen-AG**  
Ackerstraße 42  
8610 Uster  
Tel. (01) 9 44 11 11  
Fax (01) 9 44 12 33  
www.bachofen.ch  
info@bachofen.ch

### France

**THK France**  
Parc des Bruyeres  
58, Chemin de la Bruyere  
69570 Dardilly  
Tel. (04) 37 49 14 00  
Fax (04) 37 49 14 01  
www.thk.fr  
info.lys@thk-france.fr

### Austria

**THK Austria**  
Edelmüllerstraße 2  
4061 Pasching  
Tel. (0 72 29) 51 40-0  
Fax (0 72 29) 51 40-0 79  
www.thk.at  
info.lnz@thk.at

### Italy

**THK Italy**  
Via Buonarroti, 182  
20052 Monza (MI)  
Tel. (0 39) 2 84 20 79  
Fax (0 39) 2 84 25 27  
www.thk-italia.it  
info.mil@thk-italia.it

**THK Bologna**  
Via della Salute 16/2  
40132 Bologna  
Tel. (0 51) 6 41 22 11  
Fax (0 51) 6 41 22 30  
info.blq@thk-italia.it

### Sweden

**THK Sweden**  
Saldovägen 2  
17562 Järfälla  
Tel. (8) 44 57 63 0  
Fax (8) 44 57 63 9  
www.thk.se  
info.sto@thk.se

### Germany

**THK GmbH**  
**European Headquarters**  
**Düsseldorf Office**  
Hubert-Wollenberg-Str. 15  
40878 Ratingen  
Tel. (0 21 02) 74 25-0  
Fax (0 21 02) 74 25-29 9  
www.thk.de  
info.dus@thk.de

### Stuttgart Office

Heinrich-Lanz-Str. 3  
70825 Korntal-Münchingen  
Tel. (0 71 50) 91 99-0  
Fax (0 71 50) 91 99-8 88  
info.str@thk.de

### Munich Office

Max-Planck-Straße 13  
85716 Unterschleißheim  
Tel. (0 89) 37 06 16-0  
Fax (0 89) 37 06 16-26  
info.muc@thk.de

### Spain

**THK Spain**  
C/Andorra 19 A  
Sant boi de Llobregat  
08830 Barcelona  
Tel. (93) 6 52 57 40  
Fax (93) 6 52 57 46  
info.bcn@thk.de

### USA

**THK Atlanta**  
6135-E Northbelt Drive  
Norcross, GA. 30071  
Tel. (7 70) 8 40-79 90  
Fax (7 70) 8 40-78 97  
atlanta@thk.com

### THK Chicago

200 East Commerce Drive  
Schaumburg, IL. 60173  
Tel. (8 47) 3 10-11 11  
Fax (8 47) 3 10-12 71  
www.thk.com  
chicago@thk.com

### THK Detroit

4190 Telegraph Rd. Suite 2500  
Bloomfield Hill, MI. 48302  
Tel. (2 48) 5 94-75 52  
Fax (2 48) 5 94-75 58

### THK Los Angeles

6000 Phyllis Drive  
Cypress, CA. 90630  
Tel. (7 14) 8 91-67 52  
Fax (7 14) 8 94-93 15  
losangeles@thk.com

### THK New Jersey

300 F, RT.17, South  
Mahwah, NJ. 07430  
Tel. (2 01) 5 29-19 50  
Fax (2 01) 5 29-19 62  
newjersey@thk.com

### THK San Francisco

290 Lindbergh Avenue  
Livermore, CA. 94550  
Tel. (9 25) 4 55-89 48  
Fax (9 25) 4 55-89 65  
sanfrancisco@thk.com

### Canada

**THK Canada**  
130 Matheson Blvd. E., U. 1  
Mississauga, Ontario  
Canada L4Z 1Y6  
Tel. (9 05) 7 12-29 22  
Fax (9 05) 7 12-29 25  
canada@thk.de

### Brasil

**THK Brasil Ltda.**  
Rua Dr. Artur Zapponi, 57  
Freguesia do Ó  
São Paulo - SP  
Tel. (55-11) 39 24-09 11  
Fax (55-11) 39 24-09 00  
thk@thk.com.br  
www.thk.com.br

### China

**THK Beijing**  
Kunlun Hotel Room No.526  
2 Xin Yuan Lu  
Chaoyang District Beijing  
Tel. (10) 65 90-35 57  
Fax (10) 65 90-35 57

### Hongkong

**THK Shouzan Co., Ltd.**  
4/Fl., Hanyee Bldg., Flat C  
19-21 Hankow Road  
Tsimshatsui, Kowloon  
Tel. (8 52) 37 61 09 1  
Fax (8 52) 37 60 74 9

### India

**THK India**  
1050,11th Main r.p.c.  
Layout Bangalore 560040  
Tel. (0 80) 3 30-15 24  
Fax (0 80) 3 30-15 24  
thk@satyam.net.in

### Malaysia

**THK Malaysia**  
19-12-1, Mont Kiara Palma  
Jalan Mont Kiara, Off  
Jalan Bukit Kiara  
50480 Kuala Lumpur  
Tel. (03) 2 54-70 07  
Fax (03) 2 54-70 07

### Taiwan

**THK Taiwan**  
C611 SHIH, 6F, No. 7  
Wu-Chuan 1 Rd.  
Wu-Ku Kung Yeh Chu  
Hsin Chuang City  
Taipei Hsien  
Tel. (02) 22 96-49 90  
Fax (02) 22 97-81 49

## Plants

### Europe

**THK Manufacturing of Europe, S.A.S.**  
Parc d' Activités la  
Passerelle  
68190 Ensisheim  
Tel. (03) 89 83 44 00  
Fax (03) 89 83 44 09

### PGM Ball Screws Ltd.

Bodmin Road, Wyken  
Coventry CV2 5DZ  
Tel. (0 24) 76 84-19 00  
Fax (0 24) 76 61-10 32

### PGM Ireland Ltd.

18 Cookstown  
Industrial Estate  
Tallaght, Dublin 24  
Tel. (01) 4 62-81 01  
Fax (01) 4 62-90 80

### USA

**THK Manufacturing of America, Inc.**  
471 North High Street  
Hebron, OH. 43025  
Tel. (7 40) 9 28-14 15  
Fax (7 40) 9 28-14 18

### Japan

**Head Office:**  
3-11-6 Nishi-Gotanda  
Shinagawa-Ku  
Tokyo 141  
Tel. (03) 54 34-03 41  
Fax (03) 54 34-03 45  
www.thk.co.jp  
thk001@thk.co.jp

### Werke in:

Kofu, Yamaguchi,  
Yamagata, Mie, Tokyo,  
Nagoya, Osaka, Gifu,  
etc.